



Coastal Flood and Wind Event Summaries

TABLE OF CONTENTS

COASTAL FLOOD AND WIND EVENT SUMMARIES..... 1
North Atlantic Coast 1
Mid-Atlantic Coast..... 5
South Atlantic Coast 11
Gulf of Mexico Coast..... 19
U.S. Caribbean Territories 28
Great Lakes Coast..... 30
Pacific Coast 32
Hawaii and U. S. Pacific Territories 35
References..... 39

Figures

Figure 2. Hurricane Bob (1991) destroyed 29 homes along this reach of Mattapoisett, MA. 4
Figure 3. October 1991 nor'easter damage to homes at Scituate, MA. 5
Figure 4. 1962 Mid-Atlantic storm. Extreme damage to homes along the beach at Point-o-Woods,
Fire Island, NY..... 6
Figure 5. March 1989 nor'easter. This plain concrete perimeter grade beam cracked in several
places..... 8
Figure 6. March 1989 nor'easter. Although this house seems only to have lost decks and a porch,
the loss of supporting soil compromises its structural integrity. 9
Figure 7. March 1989 nor'easter. Failure of cross-bracing..... 9
Figure 8. March 1989 nor'easter. Deck pile broken by debris impact. Flood forces also caused piles
to crack at overnotched connections to floor beam. 10
Figure 9. 1992 storm impacts at Dewey Beach, DE. Note collapse of deck on landward side of
building..... 11
Figure 10. Building damage from 1926 hurricane, Miami, FL..... 12
Figure 11. Hurricane Hugo (1989), Garden City Beach, SC. House on pilings survived while others
did not..... 13
Figure 12. Hurricane Hugo (1989), South Carolina. Failure of reinforced masonry column. 14
Figure 13. Hurricane Andrew (1992). Roof failure due to inadequate bracing. 15
Figure 14: Hurricane Fran (1996). Many oceanfront houses built before the enactment of the 1986
North Carolina State Code were found to be leaning or destroyed. 17
Figure 15. No structural damage was observed to homes built to the 2001 FBC (North Captiva
Island, FL, 2004). 19
Figure 16. Galveston on two levels—the area at the right has already been raised; on the left,
houses have been lifted, but the land is still low. 20
Figure 17. Hurricane Frederic (1979). Effects of wind and water forces on unbraced pile
foundation..... 21

Figure 18. Hurricane Opal (1995), Bay County, Florida. Building damage from erosion and undermining.....	23
Figure 19. Hurricane Georges (1998), Dauphin Island, AL. As a result of erosion, scour, and inadequate pile embedment, the house on the right was washed off its foundation and into the house on the left.	25
Figure 20. This house, located in Zone AE, experienced Zone V surge and wave conditions (Santa Rosa Sound, FL, 2004).....	26
Figure 21. This elevated house on a masonry pier foundation was lost, probably due to waves and storm surge overtopping the foundation (Long Beach, MS, 2005).	27
Figure 22. Hurricane Marilyn (1995). This house lost most of the metal roof covering.	28
Figure 23. Hurricane Marilyn (1995). The roof of this house was penetrated by a large wind-driven missile (metal roof covering).....	29
Figure 24. Hurricane Georges (1998). Coastal building in Puerto Rico damaged by storm surge and waves.	30
Figure 25. House on southeastern shoreline of Lake Michigan undermined by erosion during storm of November 1951.....	31
Figure 26. 1964 Good Friday earthquake. Damage in Kodiak City, AK, caused by the tsunami of the 1964 Alaskan earthquake.....	32
Figure 27. Winter coastal storms, California and Oregon (1997– 1998). House in Pacifica, CA, undermined by bluff erosion.	34
Figure 28. Damaged building braced for structural support in La Conchita, CA, after January 2005 storm event.	35
Figure 29. Hurricane Iniki (1992). Non-elevated house at Poipu Beach that floated off its foundation and was pinned against another house and destroyed by waves.	36
Figure 30. Hurricane Iniki (1992). Undermining of shallow footings supporting columns at Poipu Beach due to lack of sufficient embedment below erosion level.	36
Figure 31. Typhoon Paka (1997). Although damaged by the storm, the concrete house in the upper part of the photograph survived, while the wood-frame house next to it was destroyed.	37
Figure 32. Tsunami damage at Poloa, American Samoa.	38

COASTAL FLOOD AND WIND EVENT SUMMARIES

This resource supplements Chapter 2 of *Coastal Construction Manual*. It summarizes coastal flood and wind events that have affected the continental United States, Alaska, Hawaii, and U.S. Territories since the beginning of this century.

Note: Hurricane categories should be interpreted cautiously. Storm categorization based on wind speed may differ from that based on barometric pressure or storm surge. Also, storm effects vary geographically—only the area near the point of landfall will experience effects associated with the reported storm category.

NORTH ATLANTIC COAST

1938, September 21 – “Long Island Express” Hurricane. The 1938 hurricane was one of the strongest ever to strike New York and New England. Although the maximum sustained wind speed at the storm’s peak was estimated at 140 mph, by landfall the wind speeds had diminished substantially (NOAA 1996). The storm, like most other hurricanes striking the area (e.g., Hurricane Gloria in 1985), had a forward speed of over 30 mph at the time of landfall, and it moved through the area rapidly. Despite its high forward speed, the storm caused widespread and significant damage to buildings close to the shoreline (see Figure 1) (surge and wave damage) as well as those away from the coast (wind and tree-fall damage). Minsinger (1988) documents the storm and the damage it caused in *The 1938 Hurricane, An Historical and Pictorial Summary*.

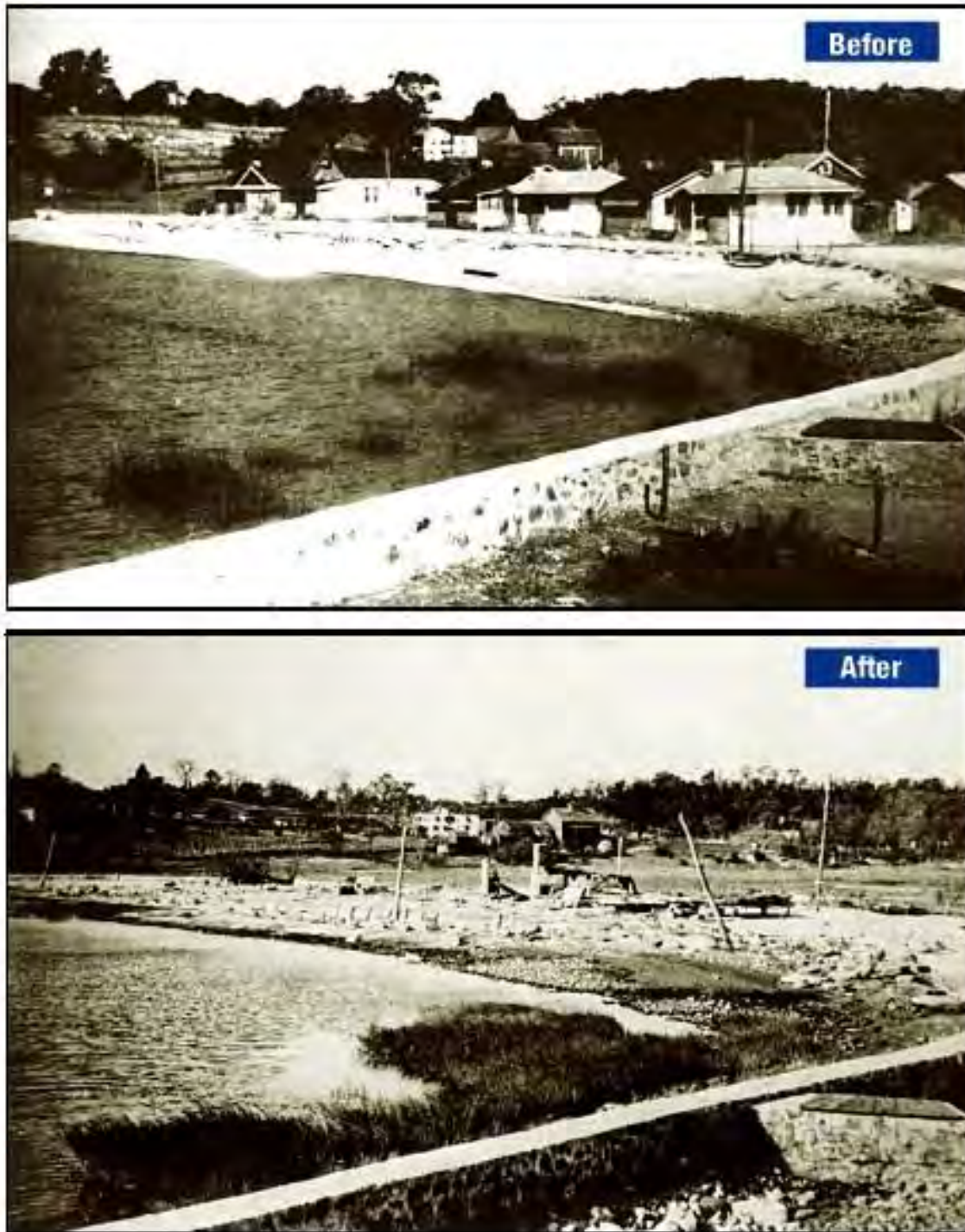

WPA photograph, from Minsinger (1988).

Figure 1. —“Long Island Express” Hurricane. Schell Beach, Guilford, CT, before and after the storm. Non-elevated houses at the shoreline were destroyed.

1985, September 27 – Hurricane Gloria, New York. This fast-moving hurricane crossed Long Island near the time of low tide, causing minor storm surge and erosion damage, but substantial wind damage. Impacts from Hurricane Gloria were documented in a FEMA Post-Flood Disaster Assessment Report. The report (URS 1986) concluded the following:

- Wind speeds on Long Island may have exceeded the code-specified 75 mph (fastest-mile) wind speed.
- Tree damage, which was widespread and substantial, led to loss of overhead utility lines and damage to buildings.
- Common causes of failures in residential construction included poor roof-to-wall connections, lack of hurricane clips, flat roofs, eaves with overhangs greater than 18 inches, and large plate glass windows facing seaward.
- The density of development, combined with high incidence of first-row roof failures, led to significant debris and projectile damage to second- and third-row buildings.

Oceanfront areas had been left vulnerable to flood, erosion, and wave damage by previous northeast storms. Accordingly, damage from Gloria included settlement of inadequately embedded pilings, loss of poorly connected beams and joists, failure of septic systems due to erosion, and water and overwash damage to non-elevated buildings.

1991, August 19 – Hurricane Bob, Buzzards Bay Area, Massachusetts. Hurricane Bob, a Category 2 hurricane, followed a track similar to that of the 1938 “Long Island Express” hurricane. Although undistinguished by its intensity (not even ranking among the 65 most intense hurricanes to strike the United States during the twentieth century), it caused \$1.75 billion in damage (1996 dollars) (see Figure 2). A FEMA Flood Damage Assessment Report (URS 1991c) documented damage in the Buzzards Bay area. The wind speeds during Hurricane Bob were below the design wind speed, and the storm tide (corresponding to a 15-year tide) was at least 5 feet below the base flood elevation (BFE). Nevertheless, the storm gave opportunity to evaluate the performance of different foundation types.

- Many buildings in the area had been elevated on a variety of foundations, either in response to Hurricane Carol (1954) or the 1978 nor’easter, or as a result of community-enforced National Flood Insurance Program (NFIP) requirements.
- Buildings that were constructed before the date of the Flood Insurance Rate Map (FIRM) for their community and that had not been elevated, or were not elevated sufficiently, suffered major damage or complete destruction; some destroyed buildings appeared to have had insufficient foundation embedment.
- Post-FIRM buildings and pre-FIRM buildings sufficiently elevated performed well during the storm. Where water was able to pass below buildings unobstructed by enclosed foundations, damage was limited to loss of decks and stairs.
- Foundation types that appeared to survive the storm without structural damage included the following:
 - a. Cast-in-place concrete columns, at least 10 inches in diameter
 - b. Masonry block columns with adequate embedment depth
 - c. 10-inch-thick shear walls with a flow-through configuration (open ends) or modified to include garage doors at each end of the building (intended to be open during a storm)



Photograph by Jim O'Connell

Figure 2. Hurricane Bob (1991) destroyed 29 homes along this reach of Mattapoisett, MA.

1991, October 31 – Nor'easter, Long Island, NY and Boston, MA. This storm, which followed closely on the heels of Hurricane Bob, was one of the most powerful nor'easters on record and is described by Dolan and Davis in *Mariners Weather Log* (1992) and Davis and Dolan in the *Journal of Coastal Research* (1991). A FEMA Flood Damage Assessment Report (URS 1992) documented damage to buildings along the south shore of Long Island and in the Boston area, and noted the following:

- Pre-FIRM at-grade buildings were generally subject to erosion and collapse; at least one was partially buried by several feet of sand overwash.
- Some buildings were damaged by flood-borne debris from other damaged structures.
- Some pile-supported buildings sustained damage as a result of inadequate pile embedment; some settled unevenly into the ground as a result of loss of bearing capacity; some were damaged as a result of collapse of the *landward* portion of the foundation (the seaward portion had been repaired after recent storms, while the landward portion was probably original and less deeply embedded).
- In areas subject to long-term erosion, buildings became increasingly vulnerable to damage or collapse with each successive storm.
- Although erosion control structures protected many buildings, some buildings landward of revetments or bulkheads were damaged as a result of wave overtopping and erosion behind the erosion control structures.

Buildings on continuous masonry block foundations (such as those permitted in Zone A) were commonly damaged or destroyed when exposed to flooding, wave action, erosion, and/or localized scour (see Figure 3).

- Buildings on continuous cast-in-place concrete foundations performed better than those on continuous masonry block foundations, and were generally more resistant to wave and flood damage; however, some continuous cast-in-place concrete foundations were damaged when footings were undermined by erosion and localized scour.



Photograph by Jim O'Connell

Figure 3. October 1991 nor'easter damage to homes at Scituate, MA.

MID-ATLANTIC COAST

1962, March 5-8 – Great Atlantic Storm of 1962 (Nor'easter). One of the most damaging storms on record, this nor'easter affected almost the entire eastern seaboard of the United States and caused extreme damage in the mid-Atlantic region. As documented by Wood (1976), the high winds associated with this slow-moving storm included peak gusts of up to 84 mph and continued for 65 hours, through five successive high tides. The combination of sustained high winds with spring tides resulted in extensive flooding along the coast from the Outer Banks of North Carolina to Long Island, NY (see Figure 4). In many locations, waves 20 to 30 feet high were reported. The flooding caused severe beachfront erosion, inundated subdivisions and coastal industrial facilities, toppled beachfront houses and swept them out to sea, required the evacuation of coastal areas, destroyed large sections of coastal roads, and interrupted rail transportation in many areas. In all, property damage was estimated at half a billion dollars (in 1962 dollars).



UPI/Corbis-Bettmann photograph

Figure 4. 1962 Mid-Atlantic storm. Extreme damage to homes along the beach at Point-o-Woods, Fire Island, NY.

1984, March 29 – Nor’easter, New Jersey. On March 28, 1984, a large low-pressure system developed in the southeastern United States and strengthened dramatically as it moved across Tennessee, Kentucky, and Virginia. In the early morning hours of March 29, the storm system moved northeastward past the Delmarva Peninsula, gaining additional strength from the Atlantic Ocean. The storm continued tracking to the northeast with near hurricane-force winds (sustained winds ranged from 40 to 60 mph). The barometric pressure dropped from a normal of 29.92 inches to 28.5 inches, and it was estimated that tides along the New Jersey coast ranged from 4 to 7 feet above normal at high tide (USDC, NOAA 1984). Measurements of local tidal flooding indicate that this storm had a recurrence interval of approximately 10 to 20 years (NJDEP 1986).

In its 1986 Hazard Mitigation Plan, the New Jersey Department of Environmental Protection (NJDEP) reported the following regarding damage from the 1984 storm: —In general, damage along the oceanfront

from this storm varied depending on whether beaches and dunes were present or absent. In more structurally fortified areas with seawalls, bulkheads, and revetments, areas usually with little or no beach, there was more structural and wave damage. In areas of moderate beaches with little or no dune protection, particularly at street ends, there was significant overwash of sand into streets and property, in addition to severe beach erosion. There was also significant amounts of sand blown down streets and onto adjacent properties in areas where there were unvegetated dunes. In areas with wider beaches and cultivated dunes, damage was limited to the ubiquitous beach erosion and scarping (or cliffing) of dunes. Because of the short duration of the storm, there was remarkably little structural damage to private homes. Undoubtedly, better building practices and better dunes instituted since the 1962 storm contributed to this fairly low loss. In more inland areas, along the baysides behind the barriers, there was significant flooding from the elevated tidal waters. Although evacuations were called for in many areas, low causeways and highways, particularly in Atlantic County, made evacuations impossible.”

1988, April 13 – Nor’easter, Sandbridge Beach, VA, and Nags Head, NC. This storm, although not major, resulted in damage to several piling-supported oceanfront houses in North Carolina and Virginia. Long-term shoreline erosion coupled with the effects of previous coastal storms (January 1987, February 1987, April 8, 1988) left these areas vulnerable to the erosion caused by the April 13 storm. The Flood Damage Assessment Report completed after the storm (URS 1989) concluded the following:

- The storm produced sustained winds in excess of 30 mph for over 40 hours; storm tide stillwater levels were approximately 3 feet above normal; the dune face retreated landward 20 to 60 feet in places.
- Several pile-supported single-family houses sustained damage to decks and main structures as a result of insufficient pile penetration; in North Carolina, the affected houses appeared to predate 1986 North Carolina Building Code pile embedment requirements.
- Post-storm inspections revealed that foundations of many of the affected houses had been repaired previously (by jetting of new piles and splicing/bolting to old piles, adding cross-bracing, or adding timber grade beams). Previous repairs were only partially effective in preventing structural damage during the storm.
- Followup examinations of some of the houses in August 1988 showed the same types of foundation repairs that had previously failed.
- Standard metal hurricane clips and joist hangers were observed to have suffered significant to severe corrosion damage. Alternative connectors, such as heavier gauge connectors, wooden anchors, or noncorrosive connectors, should be used in oceanfront areas.

1989, March 6-10 – Nor’easter, Nags Head, NC, Kill Devil Hills, NC, and Sandbridge Beach, VA. Damage from the March 1989 nor’easter was much greater than that caused by the April 1988 storm, despite lower peak wind speeds and storm surge during the latter event. The increased damage was caused by a longer storm duration (sustained winds of 33 mph for over 59 hours) coincident with spring tides. The storm reportedly destroyed or damaged over 100 cottages and motels.

In addition to reaffirming the conclusions of the FEMA report of the April 1988 storm (URS 1989), the March 1989 FEMA Flood Damage Assessment Report (URS 1990) concluded the following:

- Once undermined, plain concrete slabs, and grade beams cast monolithically with them, failed under their own weight or as a result of wave and debris loads (see Figure 5).
- Failure of the pile-to-beam connection was observed where a bolt head lacked a washer and pulled through the beam.

- Cracks in piles and deck posts, or failed connections to them, were in some cases attributed to cross-bracing oriented parallel to the shore or the attachment of closely spaced horizontal planks.
- Construction in areas subject to high rates of long-term erosion is problematic. Buildings become increasingly vulnerable to the effects of even minor storms (see Figure 6). This process eventually necessitates their removal or results in their destruction.
- Many of the buildings affected during the April 1988 storm were further damaged during the March 1989 storm, either because of additional erosion and undermining or debris damage to cross-bracing and foundation piles (see Figure 7 and Figure 8).



Figure 5. March 1989 nor'easter. This plain concrete perimeter grade beam cracked in several places.



Figure 6. March 1989 nor'easter. Although this house seems only to have lost decks and a porch, the loss of supporting soil compromises its structural integrity.



Figure 7. March 1989 nor'easter. Failure of cross-bracing.

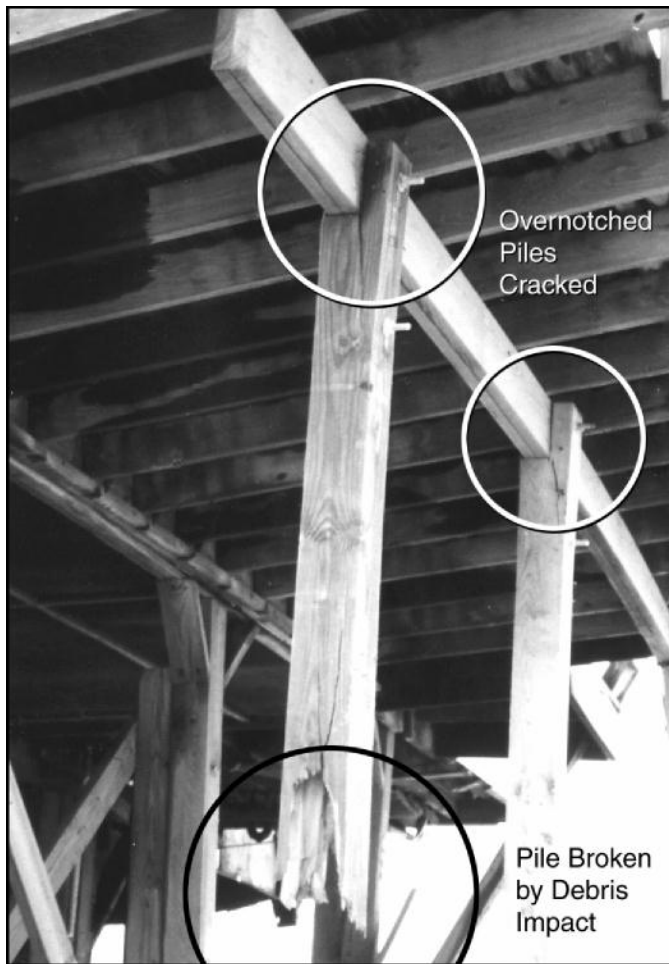

Figure 8. March 1989 nor'easter. Deck pile broken by debris impact. Flood forces also caused piles to crack at overnotched connections to floor beam.

1992, January 4 – Nor'easter, Delaware and Maryland. This nor'easter was the most intense and damaging in coastal Delaware and Maryland since the Ash Wednesday 1962 nor'easter. A FEMA Building Performance Assessment Team (BPAT) inspected damage in six Delaware and Maryland communities (see Figure 9). In their report (FEMA 1992), the BPAT concluded the following:

- Damage was principally due to storm surge, wave action, and erosion. Beaches affected by the January storm had not fully recovered from the Halloween 1991 storm, which left coastal areas vulnerable to further damage.
- Buildings constructed to NFIP requirements fared well during the storm. For those buildings damaged, a combination of ineffective construction techniques and insufficient building elevation appeared to be the major causes of damage.
- For some pile-supported buildings, inadequate connection of floor joists to beams led to building damage or failure. Obliquely incident waves are believed to have produced non-uniform loads and deflections on pile foundations, causing non-uniform beam deflections and failure of inadequate joist-to-beam connections. The report provides three possible techniques to address this problem.

Coastal Flood and Wind Event Summaries

- Some buildings had poorly located or fastened utility lines. For example, some sewer stacks and sewer laterals failed as a result of erosion and flood forces. The report provides guidance on locating and fastening sewer connections to minimize vulnerability.
- Many pile-supported buildings were observed to have sustained damage to at-grade or inadequately elevated mechanical equipment, including air conditioning compressors, heat pumps, furnaces, ductwork, and hot water heaters. The report provides guidance on proper elevation of these units.



Photograph by Anthony Pratt

Figure 9. 1992 storm impacts at Dewey Beach, DE. Note collapse of deck on landward side of building.

SOUTH ATLANTIC COAST

1926, Hurricane, Miami, FL. Those who believe we have only recently come to understand storm-resistant design and construction will be surprised by the insight and conclusions contained in a 1927 article by Theodore Eefting, a south Florida engineer, 1 year after the 1926 hurricane (see Figure 10) struck Miami, Florida (Eefting 1927). The article points out many weaknesses in buildings and construction that we still discuss today:

- Light wooden truss roof systems and truss-to-wall connections
- Faults and weaknesses in windows and doors, and their attachment to the main structure
- Poor quality materials
- Poor workmanship, supervision, and inspection
- Underequipped and undermanned building departments

Eefting makes specific comments on several issues that are still relevant:

Buildings under three stories high – “.the most pertinent conclusion that may be reached is that the fault lies in the actual construction in the field, such as lack of attention to small detail, anchors, ties, bracing, reinforcing, carpentry, and masonry work.”

The role of the designer – “Engineers and architects are too prone to write specifications in which everything is covered to the minutest detail, and to draw plans on which requirements are shown with hair splitting accuracy, and then allow the contractor to build the building, sewer, pavement or structure in general with little or no supervision.”

Building codes – “If the repeated emphasis on inspection and the importance of good workmanship we should not lose sight of the value of good building codes. . . Every city in the state whether damaged by the storm or not would do well to carefully analyze the existing codes and strengthen them where weak.”



Figure 10. Building damage from 1926 hurricane, Miami, FL.

1989, September 21-22 – Hurricane Hugo, SC. Hurricane Hugo was one of the strongest hurricanes known to have struck South Carolina. Widespread damage was caused by a number of factors: flooding, waves, erosion, debris, and wind. In addition, building and contents damage caused by rainfall penetration into damaged buildings, several days after the hurricane itself, often exceeded the value of direct hurricane damage.

Damage from Hurricane Hugo and consequent repairs were documented in a FEMA Flood Damage Assessment Report (URS 1991a) and a Follow-Up Investigation Report (URS 1991b). The reports concluded the following:

- Post-FIRM buildings that were both properly constructed and elevated survived the storm (see Figure 11). These buildings stood in sharp contrast to pre-FIRM buildings and to post-FIRM buildings that were poorly designed or constructed.



Figure 11. Hurricane Hugo (1989), Garden City Beach, SC. House on pilings survived while others did not.

- Many buildings elevated on masonry or reinforced concrete columns supported by shallow footings failed. In some instances, the columns were undermined; in others, the columns failed as a result of poor construction (see Figure 12).
- Several pile-supported buildings not elevated entirely above the wave crest showed damage or destruction of floor beams, floor joists, floors, and exterior walls.
- Some of the most severely damaged buildings were in the second, third, and fourth rows back from the shoreline. These areas were mapped as Zone A on the FIRMs for the affected communities. Consideration should be given to more stringent design standards for Coastal A Zones.
- The storm exposed many deficiencies in residential roofing practices: improper flashing, lack of weather-resistant ridge vents, improper shingle attachment, and failure to replace aging roofing materials.



Figure 12. Hurricane Hugo (1989), South Carolina. Failure of reinforced masonry column.

1992, August 24 – Hurricane Andrew, Dade County, FL. Hurricane Andrew was a strong Category 4 hurricane when it made landfall in southern Dade County and caused over \$26 billion in damage (NOAA 1997). The storm surge and wave effects of Andrew were localized and minor when compared with the damage due to wind. A FEMA BPAT evaluated damage to one- to two-story wood-frame and/or masonry residential construction in Dade County. In its report (FEMA 1993a), the team concluded the following:

- Buildings designed and constructed with components and connections that transferred loads from the envelope to the foundation performed well. When these critical “load transfer paths” were not in evidence, damage ranged from considerable to total, depending on the type of architecture and construction.
- Catastrophic failures of light wood-frame buildings were observed more frequently than catastrophic failures of other types of buildings constructed on site. Catastrophic failures were due to a number of factors:
 - a. Lack of bracing and load path continuity at wood-frame gable ends
 - b. Poor fastening and subsequent separation of roof sheathing from roof trusses
 - c. Inadequate roof truss bracing or bridging (see Figure 13)
 - d. Improper sill plate-to-foundation or sill plate-to-masonry connections



Figure 13. Hurricane Andrew (1992). Roof failure due to inadequate bracing.

- Failures in masonry wall buildings were usually attributable to one or more of the following:
 - a. Lack of or inadequate vertical wall reinforcing
 - b. Poor mortar joints between masonry walls and monolithic slab pours
 - c. Lack of or inadequate tie beams, horizontal reinforcement, tie columns, and tie anchors
 - d. Missing or misplaced hurricane straps between the walls and roof structure
- Composite shingle and tile (extruded concrete and clay) roofing systems sustained major damage during the storm. Failures were usually due to improper attachment, impacts of windborne debris, or mechanical failure of the roof covering itself.
- Loss of roof sheathing and consequent rainfall penetration through the roof magnified damage by a factor of five over that suffered by buildings whose roofs remained intact or suffered only minor damage (Sparks et al. 1994).
- Exterior wall opening failures (particularly garage doors, sliding glass doors, French doors, and double doors) frequently led to internal pressurization and structural damage. Storm shutters and the covering of windows and other openings reduced such failures significantly.
- Quality of workmanship played a major role in building performance. Many well-constructed buildings survived the storm intact, even though they were adjacent to or near other buildings that were totally destroyed by wind effects.

1996, September 5 – Hurricane Fran, Southeastern North Carolina. Hurricane Fran, a Category 3 hurricane, made landfall near Cape Fear, North Carolina. Erosion and surge damage to coastal construction were exacerbated by the previous effects of a weaker storm, Hurricane Bertha, which struck 2 months earlier. A FEMA BPAT reviewed building failures and successes and concluded the following (FEMA 1997):

- Many buildings in mapped Zone A were exposed to conditions associated with Zone V, which resulted in building damage and failure from the effects of erosion, high-velocity flow, and waves. Remapping of flood hazard zones after the storm, based on analyses that accounted for wave runup, wave setup, and dune erosion, resulted in a significant landward expansion of Zone V.
- Hundreds of oceanfront houses were destroyed by the storm, mostly as a result of insufficient pile embedment (see Figure 14) and wave effects. Most of the destroyed buildings had been constructed under an older building code provision that required that piling foundations extend only 8 feet below the original ground elevation. Erosion around the destroyed oceanfront foundations was typically 5–8 feet. In contrast, foundation failures were rare in similar, piling-supported buildings located farther from the ocean and not subject to erosion.
- A significant reduction in building losses was observed in similarly sized oceanfront buildings constructed after the North Carolina Building Code was amended in 1986 to require a minimum embedment to –5.0 feet National Geodetic Vertical Datum (NGVD) or 16 feet below the original ground elevation, whichever is shallower, for pilings near the ocean. A study of Topsail Island found that 98 percent of post-1986 oceanfront houses (200 of 205) remained after the hurricane. Ninety-two percent of the total displayed no significant damage to the integrity of the piling foundation. However, 5 percent (11) were found to have leaning foundations (see Figure 16). A non-destructive test used to measure piling length in a partial sample of the leaning buildings revealed that none of the leaning pilings tested met the required piling embedment standard. Many were much shorter. However, given the uncertainty of predicting future erosion, the BPAT recommended that consideration be given to a piling embedment standard of –10.0 feet NGVD.

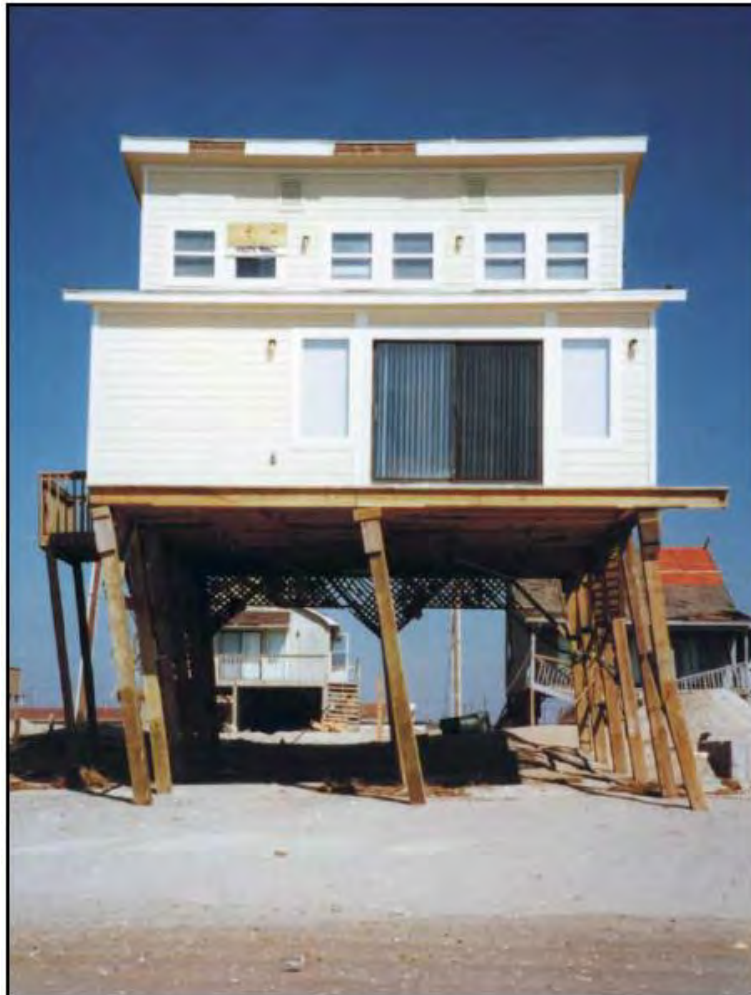

Figure 14: Hurricane Fran (1996). Many oceanfront houses built before the enactment of the 1986 North Carolina State Code were found to be leaning or destroyed.

- The BPAT noted a prevalence of multi-story decks and roofs supported by posts resting on elevated decks; these decks, in turn, were often supported by posts or piles with only 2–6 feet of embedment. Buildings with such deck and roof structures often sustained extensive damage when flood forces caused the deck to separate from the main structure or caused the loss of posts or piles and left roofs unsupported.
- Design or construction flaws were often found in breakaway walls. These flaws included the following:
 - a. Excessive connections between breakaway panels and the building foundation (however, the panels were observed generally to have failed as intended)
 - b. Placement of breakaway wall sections immediately seaward of foundation cross-bracing
 - c. Attachment of utility lines to breakaway wall panels
- Wind damage to poorly connected porch roofs and large roof overhangs was frequently observed.

- Corrosion of galvanized metal connectors (e.g., hurricane straps and clips) may have contributed to the observed wind damage to elevated buildings.
- As has been observed time and time again following coastal storms, properly designed and constructed coastal residential buildings generally perform well. Damage to well-designed, well-constructed buildings usually results from the effects of long-term erosion, multiple storms, large debris loads (e.g., parts of damaged adjacent houses), or storm-induced inlet formation/modification.

1999, September 14-17 – Hurricane Floyd, Florida to Maine. In September 1999, Hurricane Floyd briefly brushed Florida before making landfall in North Carolina as a Category 2 hurricane with maximum winds of 104 mph. Floyd moved parallel to the East Coast, becoming a tropical storm over Norfolk, Virginia and exiting as an extratropical storm in Maine. Sustained tropical storm winds and gust were recorded as far north as New York. Storm surge and torrential rains caused extensive flood damage in North Carolina where up to 20 inches of rain fell. In North Carolina, over 7,000 homes were destroyed and 56,000 were damaged. Hurricane Floyd was also a significant storm in the mid-Atlantic, with up to 14 inches of rain falling in parts of Maryland, Delaware, Pennsylvania, and New Jersey. There were 9 record floods in Mid-Atlantic rivers. The rains and high winds caused moderate flash flooding damage to coastal and inland communities along the East Coast. (NOAA 2000).

2004, August 13 – Hurricane Charley. Hurricane Charley made landfall at Mangrove Point, southwest of Punta Gorda, FL, as a Category 4 hurricane with 3-second peak gust wind speeds of 112 mph. Other measurements indicated that Hurricane Charley was a design wind event (per the Florida Building Code [FBC], the design wind speed for Punta Gorda was 114 to 130 mph 3-second peak gust).

After observing extensive wind damage, a FEMA Mitigation Assessment Team (MAT) (FEMA 2005) concluded that buildings built to the 2001 FBC generally performed well structurally (Figure 15), but older buildings experienced structural damage for a variety of reasons:

- Design wind loads underestimated wind pressures on some building components, creating some roof and framing damage
- Structural design often did not account for unprotected glazing, leading to increased internal pressures and subsequent structural failure
- Buildings lacked a continuous load path, especially at the connection between the walls and the foundations
- Corrosion of ties, fasteners, anchors, and connectors was often observed



Figure 15. No structural damage was observed to homes built to the 2001 FBC (North Captiva Island, FL, 2004).

The MAT also noted significant damage to building envelopes for many ages and types of buildings. This included roof covering blown off, siding blown off, unprotected glazing, and garage doors blown off. The envelope damaged lead to interior damage from wind and wind-driven rain, and was also a source of windborne debris.

GULF OF MEXICO COAST

1900, September 8 – Galveston, TX. This Category 4 hurricane was responsible for over 8,000 deaths. The storm caused widespread destruction of much of the development on Galveston Island and pointed out the benefits of siting construction away from the shoreline. As a result, the city completed the first, large-scale retrofitting project (see Figure 19): roads and hundreds of buildings were elevated, ground levels in the city were raised several feet with sand fill, and the Galveston seawall was built (Walden 1990).



Photograph courtesy of the Rosenberg Library, Galveston, TX.

Figure 16. Galveston on two levels—the area at the right has already been raised; on the left, houses have been lifted, but the land is still low.

1961, September 7 – Hurricane Carla, Texas. This large, slow-moving Category 4 hurricane caused widespread erosion along the barrier islands of the central Texas coast. Storm surges reached 12 feet on the open coast and 15–20 feet in the bays. Hayes (1967) provides an excellent description of the physical effects of the storm on the barrier islands, where dunes receded as much as 100 feet, where barrier island breaching and inlet formation were commonplace, and where overwash deposits were extensive. The storm and its effects highlight the need for proper siting and construction in coastal areas.

1969, August 17 – Hurricane Camille, Mississippi and Alabama. Hurricane Camille was the second Category 5 hurricane to strike the United States and the most intense storm to strike the Gulf Coast during the 20th century. According to Thom and Marshall (1971), the storm produced winds with a recurrence interval of close to 200 years and storm tides that exceeded 200-year elevations in the vicinity of Pass Christian and Gulfport, Mississippi.

Thom and Marshall characterize observed wind damage as “near total destruction” in some sections of Pass Christian and Bay St. Louis, but “surprisingly light” in areas well back from the beach – this may have been due to the relatively small size of Camille and its rapid loss of strength as it moved inland. The aerial reconnaissance performed by Thom and Richardson indicated an extremely high incidence of damage to low, flat-roofed buildings. With few exceptions, they also found that residential buildings near the beach were totally destroyed by waves or storm surge; wave damage to commercial and other buildings with structural frames was generally limited to first-floor windows, and spandrel walls and partitions.

Several publications produced after Hurricane Camille documented typical wind damage to buildings (e.g., Zornig and Sherwood 1969, Southern Forest Products Association [undated], Saffir 1971, Sherwood 1972). The publications also documented design and construction practices that resulted in buildings capable of resisting high winds from Camille. Pertinent conclusions from these reports include the following:

- The structural integrity of wood buildings depends largely on good connections between components.
- Wood can readily absorb short-duration loads considerably above working stresses.
- Six galvanized roofing nails should be used for each three-tab strip on asphalt and composition roof shingles.
- Block walls with a u-block tie beam at the top do not sufficiently resist lateral loads imposed by high hurricane winds.
- Adding a list of shape factors for roof shape and pitch would strengthen the wind provisions of the building code.
- Many homes built with no apparent special hurricane-resistant construction techniques exhibited little damage, because the openings were covered with plywood “shutters.”
- The shape of the roof and size of the overhang seem to have had a major effect on the extent of damage.

1979, September 12 – Hurricane Frederic, Alabama. Hurricane Frederic was a Category 3 hurricane that made landfall at Dauphin Island. Storm surge, wave, erosion, and wind effects of the storm caused widespread damage to non-elevated and elevated buildings (see Figure 20) (USACE 1981). For example, a post-storm assessment of coastal building damage (FEMA 1980) found that over 500 homes were destroyed along the 22-mile reach from Fort Morgan through Gulf Shores.

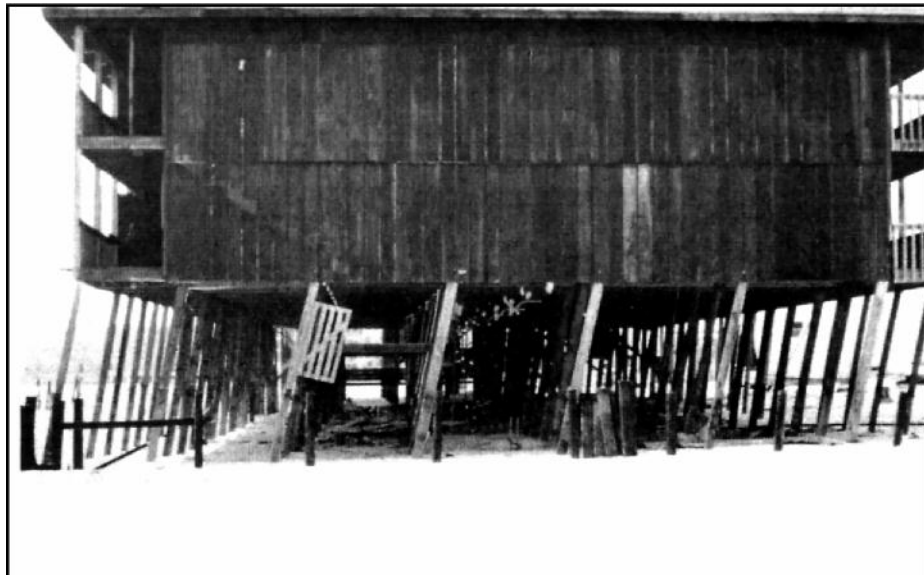

Figure 17. Hurricane Frederic (1979). Effects of wind and water forces on unbraced pile foundation.

Approximately 73 percent of front-row buildings were destroyed, while only 34 percent of second- and third-row buildings were destroyed. The destruction of non-elevated buildings was predictable; however, large numbers of elevated houses built to the BFE enforced at that time were also destroyed. Analyses confirmed that much of the damage to houses elevated to the BFE occurred because the BFE was based on the stillwater level only. It was after Hurricane Frederic that FEMA began to include wave heights in its determination of BFEs in coastal flood hazard areas.

The conclusion of the 1980 FEMA study was supported by studies by Rogers (1990, 1991), which assessed damage to buildings constructed in Gulf Shores before and after 1972, when the community adopted minimum floor elevation standards based on its first NFIP flood hazard map. In addition to showing that the adoption of the 1972 standards helped reduce damage, the 1991 study showed the value of incorporating wave heights into BFEs and noted the further need to account for the effects of erosion and overwash.

1983, August 17–18 – Hurricane Alicia, Galveston and Houston, TX. Hurricane Alicia came ashore near Galveston, Texas, during the night of August 17-18, 1983. Wind damage was extensive throughout the Galveston–Houston area, and rain and storm surge caused flood damage in areas along the Gulf of Mexico and Galveston Bay.

A study by the National Academy of Sciences (NAS 1984) states that most of the property damage resulting from Alicia was caused by high winds. Overall, more than 2,000 homes and apartments were destroyed and over 16,000 other homes and apartments were damaged. The report noted the following concerning damage to residential buildings:

- Single-family and multi-family dwellings, and other small buildings that are usually not engineered, experienced the heaviest overall damage.
- Most of the damage to wood-frame houses could easily be traced to inadequate fastening of roof components, poor anchorage of roof systems to wall frames, poor connections of wall studs to the plates, and poor connections of sill plates to foundations. In houses that were destroyed, hurricane clips were usually either installed improperly or not used at all.
- Single-family dwellings near the water were extensively damaged by a combination of wind, surge, and wave action. Some were washed off their foundations and transported inland by the storm surge and waves.
- The performance of elevated wood-frame buildings along the coast can be significantly improved through the following actions:
 - a. Ensuring that pilings are properly embedded
 - b. Providing a continuous load path with the least possible number of weak links
 - c. Constructing any grade-level enclosures with breakaway walls
 - d. Protecting openings in the building envelope with storm shutters
 - e. Adequately elevating air conditioning compressors

1995, October 4 – Hurricane Opal, Florida Panhandle. Hurricane Opal was one of the more damaging hurricanes to ever affect Florida. In fact, the state concluded that more coastal buildings were damaged or destroyed by the effects of flooding and erosion during Opal than in all other coastal storms affecting Florida in the previous 20 years combined. Erosion and structural damage were exacerbated by the previous effects of Hurricane Erin, which hit the same area just 1 month earlier.

The Florida Bureau of Beaches and Coastal Systems (FBBCS) conducted a post-storm survey to assess structural damage to major residential and commercial buildings constructed seaward of the Florida Coastal Construction Control Line (CCCL). The survey revealed that out of 1,942 existing buildings, 651 had sustained some amount of structural damage.

None of these damaged buildings had been permitted by FBBCS (all predated CCCL permit requirements). Among the 576 buildings for which FBBCS had issued permits, only 2 sustained structural

damage as a result of Opal (FBBCS 1996), and those 2 did not meet the state's currently implemented standards.

A FEMA BPAT evaluated damage in the affected area (FEMA 1996) and concluded the following:

- Damaged buildings generally fell into one of the following four categories:
 - a. Pre-FIRM buildings founded on slabs or shallow footings and located in mapped Zone V
 - b. Post-FIRM buildings outside mapped Zone V and on slab or shallow footing foundations, but subject to high-velocity wave action, high-velocity flows, erosion, impact by floodborne debris, and/or overwash
 - c. Poorly designed or constructed post-FIRM elevated buildings
 - d. Pre-FIRM and post-FIRM buildings dependent on failed seawalls or bulkheads for protection and foundation support
- Oceanfront foundations were exposed to 3–7 feet of vertical erosion in many locations (see Figure 21). Lack of foundation embedment, especially in the case of older elevated buildings, was a significant contributor to building loss.



Figure 18. Hurricane Opal (1995), Bay County, Florida. Building damage from erosion and undermining.

- Two communities enforced freeboard and Zone V foundation requirements in Coastal A Zones. In these communities, the performance of buildings subject to these requirements was excellent.
- State-mandated elevation, foundation, and construction requirements seaward of the Coastal Construction Control Line exceeded minimum NFIP requirements and undoubtedly reduced storm damage.

The National Association of Home Builders (NAHB) Research Center also conducted a survey of damaged houses (1996). In general, the survey revealed that newer wood-frame construction built to varying degrees of compliance with the requirements of the *Standard for Hurricane Resistant Residential Construction SSTD 10-93* (SBCCI 1993), or similar construction requirements, performed very well

overall, with virtually no wind damage. In addition, the Research Center found that even older houses not on the immediate coastline performed well, partly because the generally wooded terrain helped shield these houses from the wind.

1998, September 28 – Hurricane Georges, Mississippi, Alabama, and Florida. Hurricane Georges made landfall in the Ocean Springs/Biloxi, MS area. Over the next 30 hours, the storm moved slowly north and east, causing heavy damage along the Gulf of Mexico coast. According to data from NWS reports, the maximum sustained winds ranged from 46 mph at Pensacola, Florida, to as high as 91 mph, with peak gusts up to 107 mph at Sombrero Key in the Florida Keys. Storm surges over the area ranged from more than 5 feet in Pensacola, FL to 9 feet in Pascagoula, MS. The total rainfall in the affected area ranged from 8 to 38 inches.

A BPAT deployed by FEMA conducted aerial and ground investigations of building performance in Gulf coast areas from Pensacola Beach, FL, to Gulfport, MS, and inland areas flooded by major rivers and streams. In coastal areas, the BPAT evaluated primarily one- and two-family, one- to three-story wood-frame buildings elevated on pilings, although a few slab-on-grade buildings were also inspected.

The findings of the BPAT (FEMA 1999a) are summarized below:

- Engineered buildings performed well when constructed in accordance with current building codes, such as the Standard Building Code (SBC), local floodplain management requirements compliant with the NFIP regulations, and additional state and local standards.
- Communities that recognized and required that buildings be designed and constructed for the actual hazards present in the area suffered less damage.
- Specialized building materials such as siding and roof shingles designed for higher wind speeds performed well.
- Publicly financed flood mitigation programs and planning activities clearly had a positive effect on the communities in which they were implemented.

The BPAT concluded that several factors contributed to the building damage observed in the Gulf coast area, including the following:

- Inadequate pile embedment depths on coastal structures (see Figure 22)
- Inadequately elevated and inadequately protected utility systems
- Inadequate designs for frangible concrete slabs below elevated buildings in coastal areas subject to wave action
- Impacts from water-borne debris on coastal buildings
- Lack of consideration of erosion and scour in the siting of coastal buildings
- Corrosion of metal fasteners (e.g., hurricane straps) on coastal buildings



Figure 19. Hurricane Georges (1998), Dauphin Island, AL. As a result of erosion, scour, and inadequate pile embedment, the house on the right was washed off its foundation and into the house on the left.

2004, September 16 – Hurricane Ivan, Alabama and Florida. Hurricane Ivan made landfall just west of Gulf Shores Alabama as a Category 3 hurricane and moved eastward to the Florida panhandle. However, most of the impacted area experienced Category 1 winds. Although not a design wind event, a FEMA MAT observed that Ivan caused extensive envelope damage that allowed heavy rains to infiltrate buildings and damage interiors. The MAT also observed flooding in exceedance of the mapped limits of the Special Flood Hazard Area (SFHA) for many communities, and higher than the 100-year BFEs.

The wind damage highlighted weaknesses in older building stock and the need for improved guidance and design criteria for better building performance at these “low code” events. Newer buildings built to the 2001 FBC or the 200/2003 IBC generally performed well structurally. However, all types and ages of buildings sustained envelope damage and water intrusion. This led FEMA to recommend better protection of the building envelope.

Floodborne debris and wave damage that is typical in Zone V was extensive in Coastal A Zones (Figure 23). The barrier islands of Alabama and Florida experienced severe erosion, especially those with smaller, narrower beaches and dunes. Many buildings on the barrier islands collapsed due to undermining of shallow foundations (FEMA 2005b). The flood damage caused by Hurricane Ivan reinforced FEMA’s recommendation to require Zone V design and construction in Coastal A Zones, as well as the recommendation to require freeboard.



Figure 20. This house, located in Zone AE, experienced Zone V surge and wave conditions (Santa Rosa Sound, FL, 2004).

2005, August 25-30 – Hurricane Katrina, Gulf Coast. Hurricane Katrina first made landfall as a Category 1 hurricane on the southeast coast of Florida. It then moved into the Gulf of Mexico, where it gained strength over the unusually warm loop current to reach its peak as a Category 5 hurricane over the Gulf. It made its second landfall in southeast Louisiana as a strong Category 3 hurricane with 3-second gust wind speeds of approximately 150 mph. After moving northward across Breton Sound, it made a third landfall near Pearlington, MS, as a Category 3 hurricane. Due to the low pressure of the hurricane, the storm surge more closely reflected storm surge associated with a Category 5 hurricane. The near-record storm surge caused widespread damage along the coasts of Louisiana, Alabama, and Mississippi, and caused the levee system protecting New Orleans to fail. Approximately 80 percent of New Orleans was flooded. Flooding extended well beyond the SFHA in Louisiana and Mississippi, and in many places floodwaters rose above the first floor of elevated buildings (Figure 24). In contrast, Hurricane Katrina was only a design level wind event in a small area of the Mississippi coast. The economic losses exceeded \$125 billion, far surpassing the economic losses associated with Hurricane Andrew.

The FEMA MAT observed that flood damage in coastal areas resulted from velocity flooding, waves, floodborne debris, erosion, and scour. The long-duration flooding in New Orleans contributed to further damages. Where waves exceeded the elevated floor, many buildings were destroyed, leaving only parts of foundations. Where wave action was less severe, flood levels above the elevated first floor sometimes floated buildings off of their foundations. The MAT observed the following flood damage:

- The majority of one- and two-family dwellings built using Zone V construction methods had masonry pier foundations, many of which failed under lateral flood loading in one of the following four ways:

- a. Rotation of shallow footings due to inadequate embedment
- b. Separation of shallow footings or slabs at the pier connection due to inadequate reinforcement
- c. Fracture at mid-height point on the pier due to inadequate reinforcement
- d. Separation at the top of the pier at the floor system connection
- Pile foundations experienced failure at the pile-to-floor connection, but generally outperformed masonry pier foundations
- Multi-family dwellings constructed with reinforced concrete and steel frames were not significantly damaged, and damage was usually limited to interior features and contents

The total destruction of buildings by flood forces to many buildings prevented the MAT from determining wind damage to buildings that may have occurred prior to being washed off their foundations. However, where wind damage was observed, it was mostly to building envelopes and rooftop equipment. Structural damage from wind was not widespread, but did occur in older buildings built before wind effects were adequately addressed in design and construction. Structural wind damage in newer homes was a result of poor construction of connections (FEMA 2006).

After Katrina, FEMA issued new flood maps for the area that built on the hazard knowledge gained in the 25+ years since the original FIRMs were published. These flood maps continue to aid in rebuilding stronger and safer Gulf Coast communities. Following the hurricane, Louisiana adopted the 2006 I-Codes statewide.



Figure 21. This elevated house on a masonry pier foundation was lost, probably due to waves and storm surge overtopping the foundation (Long Beach, MS, 2005).

2008, September 13 – Hurricane Ike, Texas and Louisiana. Hurricane Ike made landfall over Galveston, TX, as a Category 2 hurricane with wind speeds below the design event. However, due to the large wind field and high tides when the hurricane struck, storm surge reached levels more typically associated with a Category 4 hurricane. It is estimated that the storm surge affected an area approximately 310 miles along the Gulf of Mexico coast.

The FEMA MAT observed that high waves and storm surge destroyed 3,600 of the 5,900 buildings standing on the Bolivar Peninsula before Hurricane Ike. Only about 100 buildings on the peninsula were undamaged or sustained minimal damage. Overall, houses elevated above design flood levels where the foundation was properly designed and constructed performed well. The MAT also estimated that 100 to 200 feet of vegetation and dunes were lost to erosion along a great extent of the Gulf of Mexico shoreline. Although Hurricane Ike's observed wind speeds were below the design level in the building code at the time, the MAT observed widespread light to moderate wind damage to building envelopes.

The FEMA MAT recommended the enforcement of Coastal A Zone building requirements recommended in Chapter 5 of this Manual, as well as designing critical facilities to standards that exceed current codes (FEMA 2009).

U.S. CARIBBEAN TERRITORIES

1995, September 15-16 – Hurricane Marilyn, U.S. Virgin Islands and Puerto Rico. Hurricane Marilyn struck the U.S. Virgin Islands on September 15-16, 1995. With sustained wind speeds of 120 to 130 mph, Marilyn was classified a Category 3 hurricane. The primary damage from this storm was caused by wind; little damage was caused by waves or storm surge.

As documented by the National Roofing Contractors Association (NRCA 1996), most of the wind damage consisted of either the loss of roof sections (see Figure 16)—usually metal decking installed on purlins attached to roof beams spaced up to 48 inches on center—or failures of gable ends. In addition, airborne debris penetrated roofs (see Figure 17) and unprotected door and window openings. This damage allowed wind to enter buildings and cause structural failures in roofs and under-reinforced walls. Near the tops of high bluffs, wind speedup effects resulted in damage that better represented 140-mph sustained winds.



Figure 22. Hurricane Marilyn (1995). This house lost most of the metal roof covering.

Neighbors stated that the house also lost its roof covering during Hurricane Hugo, in 1989.



Figure 23. Hurricane Marilyn (1995). The roof of this house was penetrated by a large wind-driven missile (metal roof covering).

1998, September 21-22 – Hurricane Georges, Puerto Rico. On the evening of September 21, 1998, Hurricane Georges made landfall on Puerto Rico’s east coast as a strong Category 2 hurricane. Wind speeds for Georges reported by the National Weather Service (NWS) varied from 109 mph to 133 mph (3-second peak gust at a height of 33 feet). Traveling directly over the interior of the island in an east-to-west direction, George caused extensive damage. Over 30,000 homes were destroyed, and 50,000 more suffered minor to major damage.

A BPAT deployed by FEMA conducted aerial and ground investigations of residential and commercial building performance. The team evaluated concrete and masonry buildings, including those with concrete roof decks and wood-frame roof systems, combination concrete/masonry and wood-frame buildings, and wood-frame buildings. The team’s observations and conclusions include the following (FEMA 1999b):

- Many houses suffered structural damage from high winds, even though recorded wind data revealed that the wind speeds associated with Hurricane Georges did not exceed the basic design wind speed of the Puerto Rico building code in effect at the time the hurricane struck.
- Wind-induced structural damage in the observed buildings was attributable primarily to the lack of a continuous load path from the roof structure to the foundation.
- Concrete and masonry buildings, especially those with concrete roof decks, generally performed better than wood-frame buildings; however, the roofs of concrete and masonry buildings with wood-frame roof systems were damaged when a continuous load path was lacking.
- Coastal and riverine flood damage occurred primarily to buildings that had not been elevated to or above the BFE (see Figure 18).
- Flood damage to concrete and masonry structures was usually limited to foundation damage caused by erosion, scour, and the impact of waterborne debris.
- Although some examples of successful mitigation were observed, such as the use of reinforced concrete and masonry exterior walls, too little attention had been paid to mitigation in the construction of the observed houses.

- While not all of the damage caused by Hurricane Georges could have been prevented, a significant amount could have been avoided if more buildings had been constructed to meet the requirements of the Puerto Rico building code and floodplain management regulations in effect at the time the hurricane struck the island.

As a result of recommendations made by the FEMA Building Performance Assessment Team, the Government of Puerto Rico passed emergency, and subsequently final, regulations that repealed the existing building code and adopted the 1997 Uniform Building Code (UBC) as an interim step toward adopting the International Building Code (IBC).



Figure 24. Hurricane Georges (1998). Coastal building in Puerto Rico damaged by storm surge and waves.

GREAT LAKES COAST

1940, November 11 – Armistice Day Storm, Lake Michigan. On the afternoon of November 11, high winds moved quickly from the southwest into the area around Ludington, Michigan, on the eastern shoreline of Lake Michigan. Heavy rains accompanied the winds and later changed to snow. The winds, which reached speeds as high as 75 mph, overturned small buildings, tore the roofs from others, toppled brick walls, uprooted trees, and downed hundreds of telephone and power lines throughout the surrounding areas of Mason County.

1951, November 7 – Storm on Lake Michigan. After 20 years of lower than-average levels, the water level on Lake Michigan in November 1951 was slightly above average. The November 7 storm caused extensive erosion along the southeast shore of the lake, undermining houses and roads (see Figure 32). Damage observed as a result of this storm is consistent with the concept of Great Lakes shoreline erosion as a slow, cumulative process, driven by lakebed erosion, high water levels, and storms.



Photograph courtesy of USACE, Chicago District.

Figure 25. House on southeastern shoreline of Lake Michigan undermined by erosion during storm of November 1951.

1973, April 9 – Nor’easter, Lake Michigan. This storm caused flooding 4 feet deep in downtown Green Bay, Wisconsin. Flood waters reached the elevation of the 500-year flood as strong winds blowing the length of the bay piled up a storm surge on already high lake levels. Erosion damage occurred on the open coast of the lake.

1975, November 9 and 10 – Storm on the Western Great Lakes. This storm, one of the worst to occur on Lake Superior since the 1940s, caused the sinking of the 729-foot-long ore carrier *Edmund Fitzgerald* in eastern Lake Superior, with the loss of all 29 of its crew. The storm severely undermined the harbor breakwater at Bayfield, Wisconsin, requiring its replacement the following year. Bayfield is relatively sheltered by several of the Apostle Islands. A portion of the Superior Entry rubblemound jetty was destroyed at Duluth-Superior in the eastern end of Lake Superior and had to be repaired. Storm waves on the open lake were estimated by mariners to range from 20 to 40 feet in height.

1985, March – Storms on the Great Lakes. As lake levels were rising toward the new record levels that would be set in 1986, the Town of Hamburg, New York, south of Buffalo, New York, was flooded by a damaging 8-foot storm surge from Lake Erie, which was driven by strong westerly winds. In this same month, properties along the lower sand bank portions of Wisconsin’s Lake Michigan shore experienced 10–50 feet of rapid shoreline recession in each of several weekend storms, which suddenly placed lakeside homes in peril. Some houses had to be quickly relocated.

1987, February. This storm occurred during a period of record high lake levels. Sustained northerly wind speeds were estimated to be in excess of 50 mph, and significant deepwater wave heights in the southern portion of the lake were estimated to be greater than 21 feet (USACE 1989).

1986, 1996, 1997 – Sometimes, stalled storm systems bring extremely heavy precipitation to local coastal areas, where massive property damage results from flooding, bluff and ravine slope erosion from storm runoff, and bluff destabilization from elevated groundwater. The southeastern Wisconsin coast of Lake Michigan had three rainfall events in excess of the 500-year precipitation event within 11 recent years: August 6, 1986 (Milwaukee, Wisconsin); June 16-18, 1996 (Port Washington, Wisconsin); and June 20-21, 1997 (northern Milwaukee County, including the City of Milwaukee) (SWRPC 1997). Massive property damage from flooding was reported in all three events, and Port Washington suffered severe coastal and ravine erosion during the 1996 event.

The Chicago District of the U. S. Army Corps of Engineers, using its Great Lakes Storm Damage Reporting System (GLSDRS), has estimated the total damage for storm-affected shoreline areas of the Great Lakes in 1996 and 1997 to be \$1,341,000 and \$2,900,000, respectively (USACE 1997, 1998). These amounts include damage to buildings, contents, vehicles, landscaping, shore protection, docks, and boats.

PACIFIC COAST

1964, March 27 – Alaska Tsunami. This tsunami, generated by the 1964 Good Friday earthquake, affected parts of Washington, Oregon, California, and Hawaii; however, the most severe effects were near the earthquake epicenter in Prince William Sound, southeast of Anchorage, Alaska (Wilson and Tørum 1968). The tsunami flooded entire towns and caused extensive damage to waterfront and upland buildings (see Figure 25). Tsunami runup reached approximately 20 feet above sea level in places, despite the fact that the main tsunami struck near the time of low tide. Also, liquefaction of coastal bluffs in Anchorage resulted in the loss of buildings.



(From Wilson and Tørum 1968)

Figure 26. 1964 Good Friday earthquake. Damage in Kodiak City, AK, caused by the tsunami of the 1964 Alaskan earthquake.

The 1968 report (p. 379) provides recommendations for land and waterfront buildings, including the following:

- Buildings on exposed land should have deep foundations of reinforced concrete or of the beam and raft type, to resist scour and undermining.
- Buildings should be oriented, if possible, to expose their shorter sides to potential wave inundation.
- Reinforced concrete or steel-frame buildings with shear walls are desirable.
- Wood-frame buildings should be located in the lee of more substantial buildings.
- Wood-frame buildings should be well-secured to their foundations, and have corner bracing at ceiling level.
- Wood-frame buildings in very exposed, low-lying areas should be designed so that the ground floor area may be considered expendable, because wetting damage would be inevitable. Elevated “tilt” designs of aesthetic quality should be considered.
- Tree screening should be considered as a buffer zone against the sea and for its aesthetic value.

1982-83 – Winter Coastal Storms, California, Oregon, and Washington. A series of El Niño-driven coastal storms caused widespread and significant damage to beaches, cliffs, and buildings along the coast between Baja California and Washington. These storms were responsible for more coastal erosion and property damage from wave action than had occurred since the winter of 1940-41 (Kuhn and Shepard 1991). One assessment of winter storm damage in the Malibu, CA, area (Denison and Robertson 1985) found the following storm effects:

- Many beaches were stripped of their sand, resulting in 8–12 feet of vertical erosion.
- Bulkheads failed when scour exceeded the depth of embedment and backfill was lost.
- Many oceanfront houses were damaged or destroyed, particularly older houses.
- Sewage disposal systems that relied on sand for effluent filtration were damaged or destroyed.
- Battering by floating and wave-driven debris (pilings and timbers from damaged piers, bulkheads, and houses) caused further damage to coastal development.

A 1985 conference on coastal erosion, storm effects, siting, and construction practices was organized largely as a result of the 1982-83 storms. The proceedings (McGrath 1985) highlight many of the issues and problems associated with construction along California’s coast:

- The need for high-quality data on coastal erosion and storm effects
- The vulnerability of houses constructed atop coastal bluffs, out of mapped floodplains, but subject to destruction by erosion or collapse of the bluffs
- The benefits, adverse impacts, and costs associated with various forms of bluff stabilization, erosion control, and beach nourishment
- The need for rational siting standards in coastal areas subject to erosion, wave effects, or bluff collapse

January 1988 – Winter Coastal Storm, Southern California. This storm was unusual because of its rapid development, small size, intensity, and track. While most winter storms on the Pacific coast are regional in scale and affect several states, damage from this storm was largely confined to southern California. Damage to harbor breakwaters, shore protection structures, oceanfront buildings, and

infrastructure were severe, as a result of the extreme waves associated with this storm. One study (Seymour 1989) concluded that wave heights for the January 1988 storm were the highest recorded and would have a recurrence interval of at least 100-200 years.

1997-98 – Winter Coastal Storms, California and Oregon. Another series of severe El Niño-driven coastal storms battered the Pacific coast. The distinguishing feature of the 1997-98 event was rainfall. The California Coastal Commission (1998) reported widespread soil saturation, which resulted in thousands of incidents of debris flows, landslides, and bluff collapse (see Figure 26).



Photograph by Lesley Ewing, courtesy of the California Coastal Commission.

Figure 27. Winter coastal storms, California and Oregon (1997– 1998). House in Pacifica, CA, undermined by bluff erosion.

2004/2005 – Severe Winter Storms, California. The Pacific winter storm season began in October. A series of storm systems following the same track (known as the –Pineapple Express) impacted southern California from December 27th to January 13th, bringing as much as 10 inches of rain over a few days. On January 10th, the rainfall triggered a landslide in La Conchita, CA, burying over a dozen homes and killing ten people. High winds, debris flow, and landslides damaged buildings throughout the region. Figure 27 shows a home with structural damage caused by the landslide (NOAA 2005).



Figure 28. Damaged building braced for structural support in La Conchita, CA, after January 2005 storm event.

HAWAII AND U. S. PACIFIC TERRITORIES

1992, September 11 – Hurricane Iniki, Kauai County, HI. Hurricane Iniki was the strongest hurricane to affect the Hawaiian Islands in recent memory—it was stronger than Hurricane Iwa (1992) and Hurricane Dot (1959) and caused significant flood and wave damage to buildings near the shoreline. Before Iniki, BFEs in Kauai County had been established based on tsunami effects only; following the storm, BFEs were reset based on both tsunami and hurricane flood effects. FEMA’s BPAT for Hurricane Iniki, in its report (FEMA 1993b), concluded that the following factors contributed to flood damage:

- Buildings constructed at-grade
- Inadequately elevated buildings
- Inadequate structural connections
- Inadequate connections between buildings and their pier or column foundations, which allowed flood waters to literally float buildings off their foundations (see Figure 28)
- Embedment of foundations in unconsolidated sediments (see Figure 29)
- Improper connection of foundations to underlying shallow rock

- Impact of flood-borne debris, including lava rock and parts of destroyed structures (most of the lava rock debris originated from rock landscaping and privacy walls, which were common in the area)



Figure 29. Hurricane Iniki (1992). Non-elevated house at Poipu Beach that floated off its foundation and was pinned against another house and destroyed by waves.



Figure 30. Hurricane Iniki (1992). Undermining of shallow footings supporting columns at Poipu Beach due to lack of sufficient embedment below erosion level.

The BPAT concluded that the following factors contributed to the observed wind damage:

- Inadequately attached roof sheathing and roof coverings

Coastal Flood and Wind Event Summaries

- Roof overhangs greater than 3 feet
- Inadequately designed roofs and roof-to-wall connections
- Unprotected windows and doors
- Poor quality of construction
- Deterioration of building components, principally due to wood rot and corrosion of metals
- Wind speedup effects due to changes in topography

The BPAT concluded that properly elevated and constructed buildings sustained far less damage than buildings that were inadequately elevated or constructed.

1997, December 16 – Typhoon Paka, Guam. In January 1998, FEMA deployed a Hazard Mitigation Technical Assistance Program (HMTAP) team to Guam to evaluate building performance and damage to electric power distribution systems. In its report (FEMA 1998), the team noted that damage to wood-frame buildings was substantial, but that many buildings were built with reinforced masonry or reinforced concrete and survived the storm with minimal damage (see Figure 30). Many of the roof systems were flat and many were covered with a “painted-on” coating that also survived the storm with almost no damage. At the time of the storm, Guam used the 1994 Uniform Building Code (ICBO 1994) but has adopted a local amendment specifying a design wind speed of 155 mph (fastest-mile basis).



Figure 31. Typhoon Paka (1997). Although damaged by the storm, the concrete house in the upper part of the photograph survived, while the wood-frame house next to it was destroyed.

2009, September 29 – Samoan Tsunami

In September 2009 a tsunami triggered by an earthquake off the shores of the Samoan islands hit the U.S. Territory of American Samoa. The 8.0 magnitude earthquake occurred approximately 160 miles southwest of Pago Pago (the capital of American Samoa) at the Tonga Trench, which lies at the Pacific Australia plate boundary. Within 20 minutes, a series of tsunami waves struck the island. The tsunami was the most severe to strike the island since 1917. The tsunami wave height was measured at 10 feet (peak to trough) in the harbor at Pago Pago, and runup elevations around the island generally varied from

15 to 40 feet above sea level. At least 275 residences were destroyed by the tsunami and several hundred others were damaged (Figure 31). Damage to commercial buildings, churches, schools and other buildings was also widespread. Elevated buildings and buildings farther inland generally performed better. Thirty four people were killed by the tsunami.



(Photograph courtesy of ASCE)

Figure 32. Tsunami damage at Poloa, American Samoa.

REFERENCES

- California Coastal Commission. 1998. *Coastal Impacts of the 1997-98 El Nino and Predictions for La Nina*. August 28 Memorandum to Interested Parties.
- Davis, R. E.; R. Dolan. 1991. "The 'All Hallows Eve' Coastal Storm October 1991." *Journal of Coastal Research*. Vol. 8, No. 4, pp. 978-983.
- Denison, F. E.; H. S. Robertson. 1985. "1982-1983 Winter Storms Damage, Malibu Coast." *California Geology*. September 1985.
- Dolan, R.; R. E. Davis. 1992. "Raging Northeasters." *Mariners Weather Log*. Vol. 36, No. 1, pp. 4-11.
- Eefting, T. 1927. "Structural Lessons of the South Florida Hurricane." *Florida Engineer and Contractor*. September. pp. 162-170.
- FEMA (Federal Emergency Management Agency). 1980. *Elevating to the Wave Crest Level — A Benefit-Cost Analysis*. FIA-6.
- FEMA (Federal Emergency Management Agency). 1992. *Building Performance Assessment Team, Field Trip and Assessment within the States of Maryland and Delaware in Response to a Nor'easter Coastal Storm on January 4, 1992*. Final Report. March 4.
- FEMA (Federal Emergency Management Agency). 1993a. *Building Performance: Hurricane Andrew in Florida, Observations, Recommendations and Technical Guidance*. FIA-22.
- FEMA (Federal Emergency Management Agency). 1993b. *Building Performance: Hurricane Iniki in Hawaii, Observations, Recommendations and Technical Guidance*. FIA-23.
- FEMA (Federal Emergency Management Agency). 1996. *Hurricane Opal in Florida, A Building Performance Assessment*. FEMA-28 1.
- FEMA (Federal Emergency Management Agency). 1997. *Building Performance Assessment: Hurricane Fran in North Carolina, Observations, Recommendations and Technical Guidance*. FEMA-290.
- FEMA (Federal Emergency Management Agency). 1998. *Typhoon Paka: Observations and Recommendations on Building Performance and Electrical Power Distribution Systems, Guam, USA*. FEMA-1 193-DR-GU. March.
- FEMA (Federal Emergency Management Agency). 1999a. *Hurricane Georges... In the Gulf Coast — Observations, Recommendations, and Technical Guidance*. FEMA 338.
- FEMA (Federal Emergency Management Agency). 1999b. *Hurricane Georges in Puerto Rico — Observations, Recommendations, and Technical Guidance*. FEMA 339.
- FEMA (Federal Emergency Management Agency). 2005a. *Hurricane Ivan in Alabama and Florida: Observations, Recommendations and Technical Guidance*. FEMA 489. August.
- FEMA (Federal Emergency Management Agency). 2005b. *Mitigation Assessment Team Report: Hurricane Charley in Florida*. FEMA 488. April.

- FEMA (Federal Emergency Management Agency). 2006. *Hurricane Katrina in the Gulf Coast: Mitigation Assessment Team Report, Building Performance Observations, Recommendations, and Technical Guidance*. FEMA 549. July.
- FEMA (Federal Emergency Management Agency). 2009. *Hurricane Ike in Texas and Louisiana: Mitigation Assessment Team Report, Building Performance Observations, Recommendations, and Technical Guidance*. FEMA P-757. July.
- Florida Bureau of Beaches and Coastal Systems. 1996. *Hurricane Opal, Executive Summary of a Report on Structural Damage and Beach and Dune Erosion Along the Panhandle Coast of Florida*.
- Hayes, M. O. 1967. —Hurricanes as Geological Agents: —Case Studies of Hurricanes Carla, 1961, and Cindy, 1963.” *Bureau of Economic Geology Report of Investigation No. 61*. Austin, TX: University of Texas.
- ICBO (International Conference of Building Officials). 1994. *Uniform Building Code*. Vol. 1-3.
- Kuhn, G. G.; F. P. Shepard. 1991. *Sea Cliffs, Beaches and Coastal Valleys of San Diego County: Some Amazing Histories and Some Horrifying Implications*. University of California Press
- McGrath, J., ed. 1985. —California’s Battered Coast.” Proceedings from a February 6-8, 1985, Conference on Coastal Erosion. California Coastal Commission.
- Minsinger, W.E. 1988. *The 1938 Hurricane, An Historical and Pictorial Summary*. Blue Hill Meteorological Observatory, East Milton, MA. Greenhills Books, Randolph Center, VT.
- National Academy of Sciences, National Research Council, Commission on Engineering and Technical Systems. 1984. *Hurricane Alicia, Galveston and Houston, Texas, August 17-18, 1983*.
- NAHB (National Association of Home Builders Research Center). 1996. *Assessment of Damage to Homes Caused by Hurricane Opal*, Final Report. Prepared for the Florida State Home Builders Association. January.
- NOAA (National Oceanic and Atmospheric Administration). 1996. *North Atlantic Hurricane Track Data, 1886-1996*.
- NOAA (National Oceanic and Atmospheric Administration). 1997. *The Deadliest, Costliest, and Most Intense United States Hurricanes of this Century*. NOAA Technical Memorandum NWS TPC-1. February update.
- NOAA (National Oceanic and Atmospheric Administration). 2000. *Service Assessment: Hurricane Floyd Floods of September 1999*. June.
- NOAA (National Oceanic and Atmospheric Administration). 2005. *2004/2005 Winter Storms: California and the Southwest U.S.* <http://www.ncdc.noaa.gov/oa/climate/research/2005/california-storms2005.html>. Accessed 12/1/2010.
- National Roofing Contractors Association. 1996. *Hurricane Marilyn, Photo Report of Roof Performance*. Prepared for the Federal Emergency Management Agency. March.

- New Jersey Department of Environmental Protection, Division of Coastal Resources and Division of Water Resources. 1986. *Hazard Mitigation Plan (Section 406 Plan)*. Trenton, NJ. Revised.
- Rogers, S. M. 1990. —“Designing for Storm and Wave Damage in Coastal Buildings.” *Proceedings of the 22nd International Conference on Coastal Engineering, July 2-6, 1990*. Delft, The Netherlands. B. L. Edge, ed. Vol. 3, pp. 2908 – 2921. New York: American Society of Civil Engineers.
- Rogers, S. M. 1991. —“Food Insurance Construction Standards: Can They Work on the Coast?” *Proceedings of the 7th Symposium on Coastal and Ocean Management, July 8-12, 1991*. Long Beach, California. O. T. Magoon et al., ed. Vol. 2, pp. 1064 – 1078.
- Saffir, H. S. 1971. —“Hurricane Exposes Structural Flaws.” *Civil Engineering – ASCE*. pp. 54 and 55. February.
- Seymour, R. J. 1989. —“Wave Observations in the Storm of 17-18 January, 1988.” *Shore and Beach*. Vol. 57, no. 4, October 1989, pp. 10-17.
- Sherwood, G. E. 1972. —“Wood Structures Can Resist Hurricanes.” *Civil Engineering – ASCE*. pp. 91-94. September.
- SBCCI (Southern Building Code Congress International, Inc.). 1993. *Standard for Hurricane Resistant Residential Construction*. SSTD 10-93.
- SBCCI (Southern Building Code Congress International, Inc.). 1997. *Standard Building Code*.
- Southern Forest Products Association. Undated. *How to Build Storm Resistant Structures*. New Orleans, LA.
- Southeastern Wisconsin Regional Planning Commission. 1997. Newsletter, Vol. 37, No. 3. May - June.
- Sparks, P. R.; S.D. Schiff; T. A. Reinhold. 1994. —“Wind Damage to Envelopes of Houses and Consequent Insurance Losses.” *Journal of Wind Engineering and Industrial Aerodynamics*. Vol. 53, pp. 145-155.
- Thom, H. C. S.; R. D. Marshall. 1971. —“Wind and Surge Damage due to Hurricane Camille.” *ASCE Journal of Waterways, Harbors and Coastal Engineering Division*. May. pp. 355-363.
- URS (URS Group, Inc.). 1986. *Post-Flood Disaster Assessment Report: Hurricane Gloria, September 27, 1985, South Shore, Long Island, NY*. Prepared for the Federal Emergency Management Agency. February.
- URS (URS Group, Inc.). 1989. *Flood Damage Assessment Report: Sandbridge Beach, Virginia, and Nags Head, North Carolina, April 13, 1988, Northeaster*. Prepared for the Federal Emergency Management Agency. March.
- URS (URS Group, Inc.). 1990. *Flood Damage Assessment Report: Nags Head, North Carolina, Kill Devil Hills, North Carolina, and Sandbridge Beach, Virginia, March 6-10, 1989, Northeaster*. Prepared for the Federal Emergency Management Agency. April.

- URS (URS Group, Inc.). 1991a. *Flood Damage Assessment Report: Surfside Beach to Folly Island, South Carolina, Hurricane Hugo, September 21-22, 1989*. Volume I. Prepared for the Federal Emergency Management Agency. August.
- URS (URS Group, Inc.). 1991b. *Follow-Up Investigation Report: Repair Efforts 9 Months After Hurricane Hugo, Surfside Beach to Folly Island, South Carolina*. Volume I. Prepared for the Federal Emergency Management Agency. August.
- URS (URS Group, Inc.). 1991c. *Flood Damage Assessment Report: Buzzard's Bay Area, Massachusetts, Hurricane Bob, August 19, 1991*. October.
- URS (URS Group, Inc.). 1992. *Flood Damage Assessment Report: South Shore Long Island, New York and Boston, Massachusetts Vicinity, October 1991 – Northeaster*. Draft Report. February.
- USACE (U. S. Army Corps of Engineers). 1981. *Hurricane Frederic Post Disaster Report*. Mobile, AL: Mobile District.
- USACE (U. S. Army Corps of Engineers). 1989. *Wave Information System Wind and Wave Hindcast for Burns Harbor, East of Chicago*. Chicago, IL: Chicago District.
- USACE (U. S. Army Corps of Engineers). 1997. —Annual Summary.” *Great Lakes Update*. Vol. No. 126. Detroit, MI: Detroit District. January 3.
- USACE (U. S. Army Corps of Engineers). 1998. —Annual Summary.” *Great Lakes Update*. Detroit, MI: Detroit District..
- U.S. Department of Commerce, National Oceanographic and Atmospheric Administration. 1984. *Local Climatological Data Monthly Summary: Atlantic City, NJ*.
- Walden, D. 1990. —Rising Galveston.” *American Heritage of Invention and Technology*. Vol. 5, No. 3, pp. 8-18.
- Wilson, B. W.; A. Tørum. 1968. *The Tsunami of the Alaskan Earthquake, 1964: Engineering Evaluation*. Technical Memorandum No. 25. U.S. Army Corps of Engineers, Coastal Engineering Research Center.
- Wood, F. 1976. *The Strategic Role of Perigean Spring Tides in Nautical History and North American Coastal Flooding, 1635-1976*. U.S. Department of Commerce, National Oceanic and Atmospheric Administration.
- Zornig, H. F.; G. E. Sherwood. 1969. *Wood Structures Survive Hurricane Camille's Winds*. USDA. Forest Service Research Paper FPL 123. Madison, WI: U.S. Department of Agriculture, Forest Service, Forest Products Laboratory.



Web Sites for Information About Storms, Big Waves, and Water Levels

Great Lakes Information

Adapted from *Web Sites for Information about Storms, Big Waves, and Water Levels With an Emphasis on the Great Lakes*, by Philip Keillor, 1998.

Note: The following web addresses are provided to replace the links in the 1998 article *Web Sites for Information about Storms, Big Waves, and Water Levels* that are no longer valid.

Great Lakes Information

University of Wisconsin Sea Grant Institute
<http://www.seagrant.wisc.edu>

Great Lakes Information Network
<http://www.great-lakes.net/>

Weather Systems

Continental and Statewide Weather
<http://www.weather.gov/view/national.php?map=on>

Local Weather
<http://www.crh.noaa.gov/greatlakes/>

Water Levels

Great Lakes Water Levels
<http://www.glerl.noaa.gov/data/now/wlevels/levels.html>

Great Lakes Water Levels
<http://www.lrb.usace.army.mil/>

Great Lakes Water Levels: Historic Records and Forecasts
<http://www.lre.usace.army.mil/greatlakes/hh/greatlakeswaterlevels/>

Great Lakes Water Levels Forecasts
http://www.waterlevels.gc.ca/C&A/glfkst_e.html

Great Lakes Water Levels <http://www.meds-sdmm.dfo-mpo.gc.ca/isdm-gdsi/twl-mne/index-eng.htm>

Storm Surges on the Great Lakes <http://www.lre.usace.army.mil/greatlakes/hh/weatherinformation/>

Winds and Waves

Wind and Wave Information from Buoys and Coastal Stations
<http://www.ndbc.noaa.gov/>

Dial-a-Buoy

<http://www.ndbc.noaa.gov/dial.shtml>

(Phone number - Call 888-701-8992

Commercial 301-713-9620)

Ordering Navigation Charts and Nautical Maps

<http://oceanservice.noaa.gov/>

Surface of the Earth

Great Lakes Lakebed Graphics

<http://www.ngdc.noaa.gov/mgg/greatlakes/greatlakes.html>



Internet Notes

University of Wisconsin Sea Grant Advisory Services

Web Sites for Information about Storms, Big Waves, and Water Levels with an Emphasis on the Great Lakes by Philip Keillor

Out in the North Atlantic, 75 miles east of Sable Island and 270 miles east of Halifax, Nova Scotia, Canadian data buoy No. 44139 tugs at its deep sea mooring just south of the Banquereau Bank fishing grounds.

"Throughout the day of October 28th 1991, buoy 44139 records almost no activity whatsoever... dinghy-sailing weather on the high seas. At two o'clock the needle jumps, though: suddenly the seas are twelve feet and the winds are gusting to fifteen knots [17 miles per hour]....The wind calms down again and the seas gradually subside." By evening there is a full blown storm. "The waves catch up with the wind speed around 8pm and begin increasing exponentially; they double in size every hour. After nine o'clock every graph line from data buoy 44139 starts climbing almost vertically. Maximum wave heights peak at forty-five feet, drop briefly, and then nearly double to seventy. The wind climbs to fifty knots by 9pm and gradually keeps increasing until it peaks at 58 knots. The waves are so large that they block the anemometer, and gusts are probably reaching ninety knots. That's 104 miles an hour-Gale Force 12 on the Beaufort Scale. The cables are moaning." (*The Perfect Storm* by Sebastian Junger, 1997, W.W. Norton and Company, New York, pp. 104,105.)

Maximum wave heights recorded by data buoys during the storm reached 100 feet. Vessels and their crews were caught in the storm and lost.

Imagine that you had picked up news of the storm the night of October 28, 1991. If the web site had existed then, you could have "observed" the actual weather conditions at the Banquereau Bank buoy by obtaining data being collected by the buoy during the storm.

On August 25, 1998, you could have obtained your own profile of Hurricane Bonnie-a record of the rapidly rising wind speed and wave heights and plunging air pressure at the National Oceanic and Atmospheric Administration's (NOAA's) Buoy 41002, 350 miles east of Charleston, South Carolina, as Hurricane Bonnie approached within 110 miles of the buoy. The following day, you could have observed the strength of the hurricane as the eye passed over the automated weather station at Frying Pan Shoals.

On the Internet, current wind and wave information from the Great Lakes, deep sea, and nearshore data buoys is now accessible to boaters and weather watchers. Other weather, water level, and related information is also available to anyone with a personal computer and Internet access.

These Notes provide a sample of some of the information that can be found on the Internet. More information at each site can be found by using the primary address (<http://...../>) and following routes on the sites that are not described in these focused Notes. Because sites are linked there is usually more than one route to get the information you want. Multiple sites are listed in case one site and its route to the information you need becomes overloaded or is temporarily unavailable.

An Invitation

The Internet is always changing. As you explore and find new sites of some general appeal in these topic areas, please send a brief description and the address to the author at: jkeillor@seagrant.wisc.edu

These Notes will be placed on the following Wisconsin Advisory Services' Sea Grant web page and updated frequently: http://www.seagrant.wisc.edu/advisory/coastal_engr/coast.html

Check out the University of Wisconsin Sea Grant Institute's web site.
<http://www.seagrant.wisc.edu>

Great Lakes Information

GLIN

One of the primary sites for Great Lakes information is the web site for the Great Lakes Commission's Great Lakes Information Network (GLIN). Here you will find information on historical, current, and forecasted lake levels as well as flows between the lakes, weather, and climate.
<http://www.great-lakes.net>

GLIMR

Another primary site for Great Lakes information is the Great Lakes Information Management Resource (GLIMR). This is a Canadian partner to GLIN that provides information on Great Lakes facts and figures, directories, weather forecasts, references, and a Great Lakes Atlas.
<http://www.cciw.ca/glimr/intro.html>

Weather Systems

Continental and Statewide Weather

Here's a site of special interest to boaters and other travelers. It's a map of the continental United States showing the current speed and direction of weather systems with their areas of precipitation. This map of radar images is produced by the National Weather Service (NWS) of NOAA. The radar image map is dated in UTC time (see sidebar) and is at the following site:
<http://iwin.nws.noaa.gov>

Choose one of these options: (1) *New Enhanced Graphics Version*, (2) *Graphics Version*, or (3) *Text Version*. In the New Enhanced Graphics Version, the point-and-click selections include two satellite images of the U.S., a radar image of present weather systems, and a state map of local weather forecasts. In the Graphics version, select (1) *Local Weather*, (2) your state of interest, and then (3) *Radar* in the upper left portion of the screen to get the radar image of weather systems.

In the radar images of storm systems, the underlined number is the altitude of the tops of the clouds in 100s of feet. For example, "450" refers to an altitude of 45,000 feet. The arrows indicate direction of storm movement, and the speeds are given in *knots* (meaning nautical miles per hour). Multiply the number of knots times 1.15 to get miles per hour.

Local Weather

The NWS-NOAA site listed above is linked to two commercial sites where radar images of weather systems can be enlarged to show detailed structure of weather systems at a county level. Select either (1) the *Great Links* option or (2) the *satellite, radar, and hot links* option in the Graphics Version. Then select (3) the *UCAR Radar* button. In the Enhanced Graphics Version, select the *USA Composite* buttons for either Weather Services International or The Weather Channel.

Time on the Web

Some web sites indicate time in terms of Greenwich Mean Time (GMT), UTC (Universal Coordinated Time), or Zulu Time (Z) on a 24-hour clock with no need for an AM or PM distinction. The three terms mean the same thing. Subtract four hours from GMT, UTC, or Z time to get Eastern Daylight Time (EDT). Subtract five hours to get Eastern Standard Time (EST) or Central Daylight Time (CDT). Subtract six hours to get Central Standard Time (CST). For example, a map of NEXRAD Radar images produced at 1400 hours UTC was produced at 10 am EDT and 9 am CDT. A map of NEXRAD Radar images produced at 1800 hours UTC was produced at 2 pm EDT and 1 pm CDT.

Water Levels

Coastal U.S. Sea Levels

Oceanographic Products and Services Division, National Ocean Service, NOAA. This site contains preliminary, recent, and historic tidal and other water level information for U.S. harbor gauge sites (including the Great Lakes, Hawaii, Alaska, and Puerto Rico).

http://www.opsd.nos.noaa.gov/data_res.html

Great Lakes Water Levels

The above site also contains recent (preliminary) or historic (verified) lake levels (six-minute, hourly) for period of choice at 28 U.S. recording sites on the Great Lakes.

Great Lakes Water Levels

Great Lakes Environmental Research Laboratory (GLERL)- NOAA. Recent (preliminary) or historic (verified) hourly lake levels for the period of choice for 17 U.S. recording sites on the Great Lakes, Great Lakes surface water temperature contour maps, satellite imagery, and NOAA-National Data Buoy Center (NDBC) midlake buoy data.

<http://www.glerl.noaa.gov/data/data.html>

Great Lakes Water Levels

Buffalo District, U.S. Army Corps of Engineers (USACE). Interactive plots of historic monthly mean Great Lakes water levels (some from as far back as 1860). The time series of lake levels are from one reference water level gauging station on each lake. Also available: mean, maximum, and minimum levels with standard deviation at each gauge site plus daily average lake levels for the current week; recent past, current, and forecast water levels on the Upper St. Lawrence River between Kingston, Ontario, and Montreal, Quebec; other water level and outflow information for Lakes Erie and Ontario.

<http://hank.ncb.usace.army.mil>

Great Lakes Water Levels: Historic Records and Forecasts

Detroit District, USACE, Great Lakes Hydraulics and Hydrology Branch Home Page.

<http://sparky.nce.usace.army.mil/hmpghh.html>

Select one of the *Great Lakes* by clicking on the map. On each lake's page, you will find a six-month lake level forecast, long-term average level and year-to-date average levels, historic levels from 1918 to a recent year, and precipitation from 1918 to yesterday. A table of probable storm rise (surge) values is also available.

Select *Water Levels*. Choose from recent water level data, daily average lake levels and connecting channel water levels, and forecasted water levels. Under *forecasted water levels*, choose from a weekly forecast of Great Lakes lake levels, bimonthly forecast of water depths in connecting channels, six-months forecast of lake levels, a monthly *Lake Level Update* newsletter, and a table of average and extreme lake levels. A table of probable storm rise (surge) values is also available.

Great Lakes Water Levels Forecasts

Canadian Hydrographic Service, Department of Fisheries and Oceans, Canada. Lake level forecasts for the next six months are presented in a table format; including high, most probable, and low forecast lake levels.

<http://chswww.bur.dfo.ca/danp/glfctst.html>

Great Lakes Water Levels

Marine Environmental Data Service, Department of Fisheries and Oceans, Canada. Most recent daily and weekly mean and highest and lowest water levels at master water level gauges for each lake.

http://www.meds.dfo.ca/meds/products/e_pt_wlb.html

Great Lakes Water Levels

Great Lakes water levels are available at the GLIN site: <http://great-lakes.net>

Click your way through *Great Lakes* to *hydrology: levels*. This site also contains graphs of mean monthly lake levels from 1918 to the present and beginning-of-the-month lake levels for 1860 to 1990. You can quickly get to these *hydrographic charts* at:

<http://great-lakes.net/envt/water/levelsh.html>

Present Water Levels by Phone

The Canadian Hydrographic Service, Department of Fisheries and Oceans, provides Voice Announcing Water Level Gauging Stations that give present water levels at 31 stations along the Canadian shores of the Great Lakes plus 6 stations along the shores of the upper St. Lawrence River. Push-button, cellular, or rotary phones can be used. There is a phone number given for each water level recording station at the following address:

<http://chswww.bur.dfo.ca/danp/voice.html>

Storm Surges on the Great Lakes

Detroit District, USACE. Storm probability tables, by lake and by month (only recent months) and storm water level rise at key locations, for these probabilities: 20%, 10%, 3%, 2%, and 1%.

<http://sparky.nce.usace.army.mil/levels/stpbtb.html>

Winds and Waves

Wind and Wave Information from Buoys and Coastal Stations

Buoy and station information, real-time data, archived data, and an index of deep water buoys and coastal or nearshore Coastal-Marine Automated Network (C-MAN) stations are available from NOAA's NDBC. <http://seaboard.ndbc.noaa.gov/>

Select (1) *Real-Time Data*, (2) *NDBC Station locator map*, (3) regional map for location of stations in your area of interest, and (4) station locations of interest on the map. At each station page, you get a description and photo of the station and current conditions of air/sea temperature, atmospheric pressure, wind, and wave conditions. You also can get the latest marine forecast with Notice to Mariners, graphs of conditions over the past few days and a table of the previous 12 observations.

Select *Dial-a-Buoy* to get an explanation of a system for obtaining the wind and wave conditions from any of NOAA's 65 data buoys or the Coastal-Marine Automated Network's (C-MAN) 54 stations in United States coastal and Great Lakes waters by phone.

Dial-a-Buoy

From a push-button phone, you can get present air/sea conditions at automated stations. Anywhere. Anytime. Dial: 228-688-1948. Then follow the verbal prompts (without entering digits too fast). If the web is too busy or if the computer system received your inputs too rapidly, you may need to repeat your phone call. Most stations will also allow you to get the latest National Weather Service forecast for the same area.

Before you place your call, you will need the NOAA buoy or C-MAN station identifier number, or the latitude and longitude of the station location. The station identifier number is much easier to enter by phone. To get this information, access the *station locator map* on the NDBC site given above, or at the following NOAA National Weather Service site.

Wind and Wave Information from Buoys and Coastal Stations

One of the most direct links to the information from automated buoys and coastal stations worldwide is NOAA's National Weather Service site in Tallahassee, Florida.

<http://www.nws.fsu.edu/buoy/>

On the site's global map, select the box for the area from which you want information. An enlarged map of that area shows locations of automated weather recording stations. Click on the station you want for a detailed location map. Very recent observations of wind speed and direction, air temperature, surface water temperature, and wave heights at that station are given along with the latest marine forecast for that site.

Wind and Wave Information for the Great Lakes Only

The NOAA (GLERL) site at Ann Arbor, Michigan, provides access to C-MAN station and NDBC data buoy weather conditions (buoy data are available only from May to November) for the past 36 hours, including winds and waves. This site also offers current marine weather forecasts and a table of months and years for which NDBC buoy data are available.

<http://www.glerl.noaa.gov/data/data.html>

A Global Ocean View of Waves

A global view of present and forecasted ocean wave heights and direction of movement can be seen on one screen. Enlarged views are available for five separate oceans: the North and South Atlantic, the North and South Pacific, and the Indian oceans. This information is available from NOAA's Shipboard Environmental Data Acquisition System (SEAS):

<http://seas.nos.noaa.gov/seas/>

Click on (1) the image of global sea surface temperatures to get *Oceanographic Models*, (2) select *WAMI.0* or click on the map of global waves on the right of the screen. WAM stands for Wave Model. (3) select the present conditions (T0000) or forecast conditions for different future intervals (Txxxx) up to 120 hours (five days) for any of the above oceans. Then the full-screen global ocean map with wave heights and directions will appear. Different color bands represent significant wave heights from 2 to 40 feet. Significant wave heights are the average of the highest one-third of waves present. This value also represents the height of waves estimated by a trained observer. Select an enlarged view of an ocean of interest to you.

Great Lakes Coastal Forecast System

Information on winds, waves, and surface water temperatures is available from the web site of NOAA-GLERL in Ann Arbor, Michigan.

<http://www.glerl.noaa.gov/>

Select (1) *Great Lakes Coastal Forecasting System*, (2) *Nowcast Maps*. A map of present surface water temperatures for Lake Erie appears. Select (3) *show all* in the upper left portion of the screen. Lake Erie maps of surface water temperature, elevation, water currents, wind field, wave heights, and direction appear along with a plot of recent water elevations at Buffalo, Cleveland, and Toledo and vertical profiles of water temperatures across the lake. Go back to *Nowcast Maps*. Select *Superior* or *Michigan* for a Great Lakes map of wind fields over each of the lakes. Select *show all* in the upper left portion of the screen to get both the wind field maps and the wave height maps for all of the Great Lakes.

Climate and Weather Information

NOAA's National Climatic Data Center (NCDC) in Asheville, North Carolina, is the major source of archived weather and climatic data for the United States. Some information is available on-line:

<http://www.ncdc.noaa.gov>

The site offers a climate visualization system that allows visual browsing of data available on line at the NCDC. Select (1) *climate resources*, (2) *get/view online climate data*, and (3) *climate visualization*. To get radar images of weather systems for a particular day, month, or year, go back to the main page. Select (1) the *radar* tab, (2) *get/view online radar data*, and (3) *National Mosaic Reflectivity Images*. There is also information on climate extremes, weather events, and other subjects of interest.

Wave Climate Information

Coastal Engineering Research Center, Waterways Experiment Station, The U.S. Army Corps of Engineers. The following site has information on how to obtain written reports containing hindcast (predicted past) coastal deepwater wave conditions from the Wave Information Study (WIS). A 20-year record for the Atlantic, Gulf, and Pacific coasts (1956-1975); a 32-year record for Great Lakes coasts (1956-1987); and a new 20-year record for the Atlantic coast that includes hurricanes (1975-1995).

<http://bigfoot.cerc.wes.army.mil/>

The above site is that of the U.S. Army Corps of Engineers' Coastal Hydraulics Laboratory, which includes the Coastal Engineering Research Center. The laboratory and center are part of the Waterways Experiment Station in Vicksburg, Mississippi.

The WIS reports can be followed by selecting (1) the *Information* symbol, (2) *Coastal Engineering Information Search*, (3) *Research Library*, (4) *Publications*, (5) *Coastal Engineering Publications*, (6) *Wave Information Studies (WIS) Related Publications* and (7) *Reports*. In the Reports section, scroll down through a long list of out of print or superceded publications until you get to the WIS report that gives wave information for your area of interest. The Reports section also gives addresses and information for ordering copies of the WIS reports.

Ocean Images from the Space Shuttle

The following site has a list of still images taken from various shuttle flights. Images include coasts, islands, local wind effects, waves, and pollution.

http://daac.gsfc.nasa.gov/CAMPAIGN_DOCS/OCDST/shuttle_oceanography_web/oss_contents.html

Oceanography and Weather for K-12 Teachers

Visit the Woods Hole Oceanographic Institution's home page:

<http://www.whoi.edu/index.html>

Select *Animation and Video Gallery* for a set of animations and videos that explain the activities of the Institution. This requires software capable of handling video and animation.

Or, select (1) *Education Programs*, (2) *K-12*, (3) *K-12 Resources*, and (4) *Weather* to get descriptions of specific products to explain weather to primary and secondary school students.

Ordering Navigation Charts and Nautical Maps

National Ocean Service, NOAA. Listed under Products and Services: nautical charts, tide tables, and the Great Lakes Hydrograph (a multidecade graph of mean monthly lake levels).

<http://www.nos.noaa.gov/>

Canadian Hydrographic Service, Department of Fisheries and Oceans, Canada.

http://www.chshq.dfo.ca/chs_hq/prodserv.html

Surface of the Earth

Look at the following National Geophysical Data Center (NGDC) web site for surface features of the land and seafloors of the world.

<http://www.ngdc.noaa.gov>

Select: (1) *Marine Geology and Geophysics (MGG)*, (2) *Images* (on the left side of the screen), and follow additional steps to get the information indicated below:

Surface of the Earth

Select (3) *Global Relief*, and (4) *Surface of the Earth Poster*.

Beneath the Watery World

Select (3) *Estimated Seafloor Topography from Satellite Altimetry*, (4) click on the *rotating globe*. Under Quick Contents, select (5) *Globe Gallery or Image Gallery-NOAA*. Under *Image Gallery-NOAA*, select (6) *New Global Seafloor Topography from Satellite Altimetry*, then choose (7) one of the images available for a *World View* or regional views.

A Wild Flight over the Bottoms of Lakes Superior and Michigan

Go to *Images* and select (1) *Great Lakes Geomorphology*, and (2) *Go for a wild animated GIF (or .mpeg) ride over Lake Superior and Lake Michigan*. To observe the route of this flight, look at the following site:

http://www.ngdc.noaa.gov/mgg/image/IR_Path.GIF

Great Lakes Lakebed Graphics

At the same NGDC web site, go to (1) *Images*, select (2) *Great Lakes Geomorphology*, then select (3) *Bathymetry of (name of lake) Poster*. In August 1998, color images of the lakebeds of Lakes Michigan, St. Clair, and Erie are available.

This work was funded by the University of Wisconsin Sea Grant Institute under grants from the National Sea Grant College Program, National Oceanic & Atmospheric Administration, U.S. Department of Commerce, and from the State of Wisconsin. Federal Grant No.NA46RG0481, Project C/C-1.

WISCU-G-98-003

Sea Grant — a unique partnership with public and private sectors combining research, education, and technology transfer for public service — is the national network of universities meeting the changing environmental and economic needs of people in our coastal, ocean, and Great Lakes regions.

Author * Philip Keillor
Editor * Elizabeth Seaman

Additional copies of this publication are available free of charge from:

Communications Office
UW Sea Grant Institute
1800 University Avenue
Madison, WI 53705-4094

Email:linda@seagrants.wisc.edu

Copyright 1998
Board of Regents * University of Wisconsin System
Sea Grant Institute





Dune Walkover Guidance

This resource contains copies of the following two publications, which provide design criteria for beach walkover structures:

Beach/Dune Walkover Guidelines, by the Florida Bureau of Beaches and Coastal Systems, Florida Department of Environmental Protection, Revised January 2006.

Beach Dune Walkover Structures, SUSF-SG-76, by Todd L. Walton, Jr., and Thomas C. Skinner. Published by the Marine Advisory Program of the Florida Cooperative Extension Service and the Florida Sea Grant, March 1983.



Beach and Dune Walkover Guidelines

Florida Department of Environmental Protection
Division of Water Resource Management
Bureau of Beaches and Coastal Systems
3900 Commonwealth Boulevard, MStation
Tallahassee, Florida 32399-3000
(850) 488-7708

On many of Florida's beaches, sand dunes and coastal vegetation provide significant protection to upland property, upland development, and the beach dune system. The Florida Department of Environmental Protection (DEP) encourages the design of beach access, including beach and dune walkovers, to protect the dune topography and dune vegetation from pedestrian traffic and allow for the natural recovery of damaged or eroded dunes.

PERMIT REQUIREMENTS

A permit from DEP is required for construction of walkovers on most sandy beaches fronting on the open waters of the Atlantic Ocean or Gulf of Mexico. In areas where a Coastal Construction Control Line (CCCL) has been established pursuant to provisions of Section 161.053, Florida Statutes (F.S.), a permit is required for all excavation, construction, or other activities with the potential to cause beach erosion or damage coastal vegetation. On sandy shorelines where a CCCL line has not been established, a permit is required for construction activities within 50 feet of the mean high water line (see Section 161.052, F.S.).

Permits for walkovers contain standard conditions that require construction to be conducted in a manner that minimizes short-term disturbance to the dune system and existing vegetation. Replacing vegetation destroyed during construction with similar plants suitable for beach and dune stabilization is required. Only limited excavation for the placement of support posts is authorized, and construction of walkovers may not occur during the marine turtle-nesting season, which extends May 1 through October 31 (except for Brevard through Dade counties, which extends March 1 through October 31).

GENERAL SITING GUIDELINES

The walkover shall be designed and sited to protect dune features, to minimize disturbance of native vegetation, to not restrict lateral beach access and to minimize the amount of construction material that may become debris during a storm. Elevated walkovers are not required for all beach accesses, such as in sparsely vegetated, low profile dune areas where on-grade sand or shell paths are suitable for controlling foot traffic. Walkovers should generally be constructed perpendicular to the shoreline and extend at least to the seaward toe of the frontal dune or the existing line of vegetation but not farther than 10 feet seaward of the vegetation. The optimum siting of the walkover structure can be determined by contacting a CCCL field inspector.

GENERAL DESIGN GUIDELINES

Walkovers are designed to be minor, expendable structures that pose a minimal interference with coastal processes and generate minimal amounts of debris. Walkovers constructed across native beach and dune vegetation should be post-supported and elevated a sufficient distance above the existing or proposed vegetation to allow for sand build-up and clearance above the vegetation. Whenever possible, stairways and ramps leading from the dune bluff or crest down to the beach should be designed with posts that completely span the seaward slope of the dune. The structure should be designed to minimize the quantity of material used in construction, such as avoiding the use of vertical wood pickets, and reducing the length and width of construction on the beach.

Single family walkovers should not exceed 4 feet in overall width and the support posts shall not be greater than 4-inch wide posts. Multi-family walkovers shall not exceed 6 feet in overall width and the support posts shall not be greater than 6-inch wide posts. Round posts are preferred to square posts. Support posts shall not be

encased in concrete nor installed into dune slopes that are steeper than approximately 30 degrees. Support posts should have a minimum 5 feet of soil penetration. Applicants should consult with the Bureau prior to requesting a permit for a walkover that contains switchbacks, long ramps or other features required to comply with the Americans with Disabilities Act Accessibility Guidelines.

WALKOVER ELEVATION GUIDELINES

Site conditions affecting walkover heights vary as the structure traverses the beach/dune system. The ground cover changes from the uplands, commonly covered with woody scrub or coastal strand vegetation (saw palmetto/sea grape/scrub oaks), over a dune bluff or one or several dune crest(s), covered with either coastal strand or coastal grassland (sea oats/bitter panicum/marsh hay), down the slope to the dry sand beach, either uncovered bare escarpment or partially covered with beach/dune vegetation (railroad vine/sea rocket/sea oats). The type of structure and height from the dune bluff or crest down to the beach also must be considered in setting the walkover elevation. Increased elevation of the structure requires a longer run to the beach and additional construction material within this high energy area. This creates additional storm generated debris, sea turtle nesting habitat impacts, sand losses due to storm wave scour, and interferes with people's ability to walk along the beach.

Walkover Elevations in Uplands. The upland environment of coastal scrub/coastal strand habitat is characterized by more stable soil conditions with less blowing sands and infrequent storm overwash events. The stable conditions allow for the development of a mature woody vegetation and saw palmetto dominated plant community. In addition to thick above ground stem and leaf vegetation between 5 and 15 feet in height, this plant community has an extensive below ground woody root mat. Walkovers in these upland habitats need be elevated only a sufficient distance above the ground to avoid disturbance of the soil and root systems or cutting of low tree and palmetto trunks. An elevation of the stringers from 6" to 2'-0" above existing grade should be sufficient. Walkover elevations crossing coastal wetlands within upland areas may require increased elevations. Elevation of the walkover above the leaf canopy is in most cases impractical in coastal scrub or coastal strand habitats.

Walkover Elevations over Bluffs. The low stringer elevation recommended for uplands can be carried to an eroded bluff line. This will reduce the length of a ramp or walkover down to the beach. Again the objective the walkover elevation is to reduce damage to coastal scrub soils and root systems.

Walkover Elevations over Dune Crests. Dune environments are characterized by mobile sands subject to storm effects (which lower grade elevations) and wind effects (which can raise elevation as sand is trapped). Dunes are dominated by coastal grassland plants adapted to the dynamic environment. These include sea oats, bitter panicum, and little bluestem. Walkovers sited within active dune systems are required to be elevated sufficiently to allow for sand movement and growth of vegetation. Walkover designs published in "Beach/Dune Walkover Structures" referenced below specify a 3'-10" minimum clearance from existing grade to the bottom of the stringers of an up to 6-foot wide (overall dimension) multi-family or public beach access structures, and a 3'-0" minimum clearance to the top of the deck for an up to 4-foot wide single family structures.

Walkover Elevations on Seaward Dune or Bluff Slopes. The elevation of the walkover at the dune crest and the distance of the seaward terminus from the water's edge determine the height of the steps or ramps crossing the seaward slope. The design objective is to get the structure down to the beach in as short a shore-normal (perpendicular to the shoreline) distance as possible while reducing the shore-parallel coverage of the slope. Department guidelines require that the seaward terminus of the structure be no farther seaward than 10 feet from the line of permanent beach dune vegetation or the toe of the frontal dune. Reducing the seaward encroachment and shore-parallel width decreases the potential for storms interacting with the structure, occupation of sea turtle nesting habitat by the structure, and interference with lateral public beach access. Walkovers designed for the Americans with Disabilities Act often increase the length of walkover ramps on the beach. This requires the need for a site specific review for environmental impacts. The burial of the ramp or

step terminus a minimum amount (0.5 to 1.0 feet)-foot below grade may allow for use of the walkover after some lowering of the beach elevation from minor storms. However, placement of this terminus below the depth of a post storm beach profile is discouraged as this portion of the walkover will most likely have been damaged by larger storms and to have interfered with coastal processes.

On Grade Walkovers. Elevated walkovers are not necessary in all site conditions and use situations. Where dune development is minimal, beach dune vegetation sparse or use infrequent, on-grade footpaths may be preferred. The Department discourages solid concrete walks and footpath surfaces such as stepping stones that create debris or missiles. Other surfaces such as geotextile fabrics, cabled wood planks, or shell require a case by case review. No permanent path surfaces are allowed seaward of the dune or within sea turtle nesting habitat.

TYPICAL WALKOVER PROFILE

⇨ To the Beach

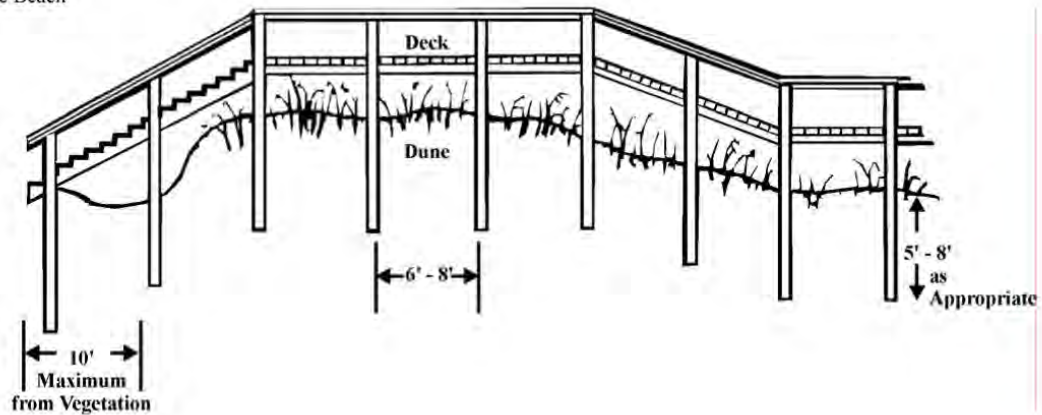

References

Beach/Dune Walkover Guidelines, the Florida Bureau of Beaches and Coastal Systems, Florida Department of Environmental Protection, Revised January 1998.

Beach/Dune Walkover Structures, SUSF-SG-76 by Todd L. Walton, Jr., and Thomas C. Skinner. Published by the Marine Advisory Program of the Florida Cooperative Extension Service and the Florida Sea Grant, March, 1983.



MAP-18

Beach Dune Walkover Structures

Todd L. Walton, Jr. and Thomas C. Skinner

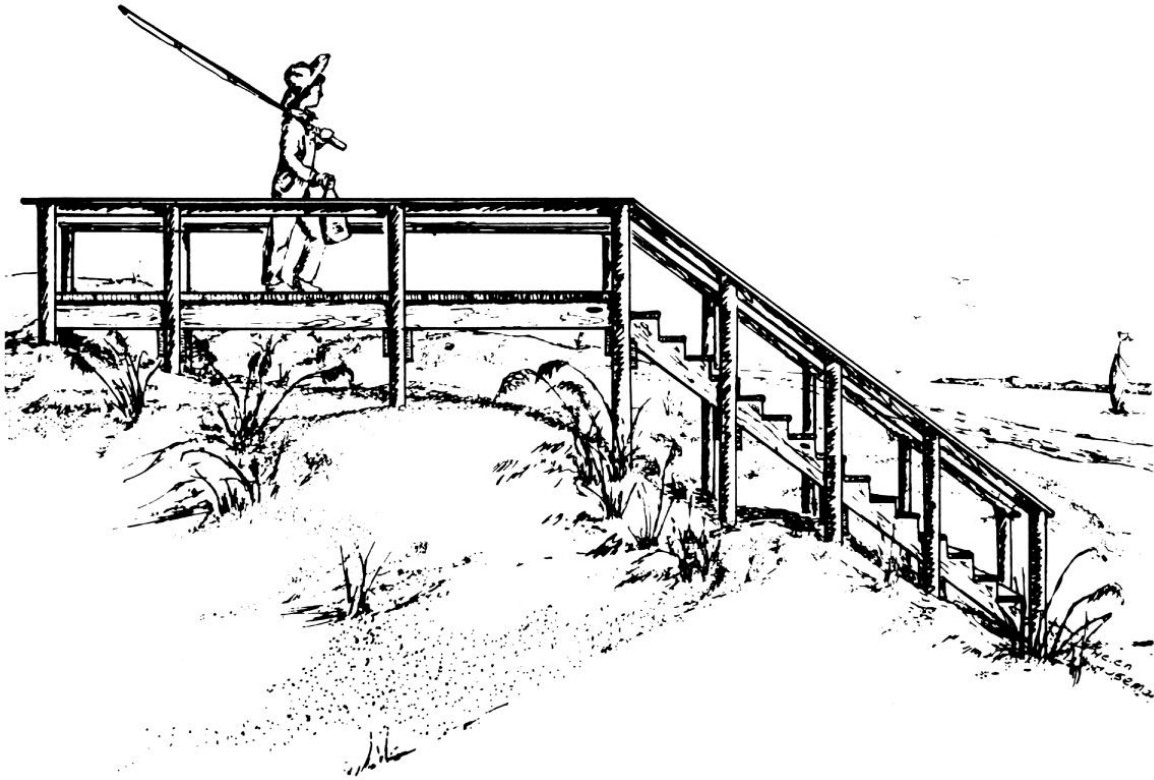

Florida Cooperative Extension
Marine Advisory Bulletin

MARCH 1983*

The State University System of Florida Sea Grant College is supported by award of the Office of Sea Grant, National Oceanic and Atmospheric Administration, U. S. Department of Commerce, grant number NA80AA-D-00038, under provisions of the National Sea Grant College and Programs Act of 1966. This information is published by the Marine Advisory Program which functions as a component of the Florida Cooperative Extension Service, John T. Woeste, dean, in conducting Cooperative Extension work in Agriculture, Home Economics, and Marine Sciences, State of Florida, U. S. Department of Agriculture, U. S. Department of Commerce, and Boards of County Commissioners, cooperating. Printed and distributed in furtherance of the Acts of Congress of May 8 and June 14, 1914. The Florida Sea Grant College is an Equal Employment Opportunity-Affirmative Action employer authorized to provide research, educational information and other services only to individuals and institutions that function without regard to race, color, sex, or national origin.

This public document was promulgated at a cost of \$166.25 or 11 cents per copy, to provide information on construction of beach dune walkover structures. Cost does not include postage and handling.

12/3M/76
11/1M/81
3/1.5M/83

*This publication is a reprint with revisions of Marine Advisory Bulletin SUSF-SG-76-006 originally published in 1976. The number has been changed to MAP-18.

BEACH DUNE WALKOVER STRUCTURES

by

Todd L. Walton, Jr.¹ and Thomas C. Skinner²

INTRODUCTION

The idea behind this publication originally came from the Bureau of Beaches and Shores, Department of Natural Resources, State of Florida. It was recognized that numerous dune systems within our state were undergoing destruction due to the loss of vegetation caused by unrestricted access to the beach over the dune systems. As the vegetation was lost, the wind became capable of eroding the dune and caused a progressive deterioration of the entire dune system.

In areas of high human traffic, a beach walkover structure is needed to save this vegetation. Two structure designs are presented in this publication. Figures 1 through 7 give details of a structure for use in areas of heavy foot traffic. A good example of such use might be for a condominium or a community public access ramp. The depths of pilings account for both depth necessary for structure stability and added depth to account for possible dune deflation losses.

Figures 8 and 9 give details of a smaller structure more suitable for the typical coastal land owner where only light foot traffic is expected. The depth of pilings in sand is correspondingly less which should minimize interference with the dune system in construction of the walkway. It should be noted that any construction seaward of the State Coastal Construction

¹ Coastal Engineering Advisory Specialist, Marine Advisory Program, with the Coastal and Oceanographic Engineering Laboratory, University of Florida.

² Extension Agricultural Engineer, Florida Cooperative Extension Service, IFAS University of Florida.

Setback Line (Reference 1) must be permitted by the Bureau of Beaches and Shores, Department of Natural Resources.

The designs are basic enough such that various alternatives can be added to the designs without altering the structures to a great degree. One such alteration would be a transverse extension of the deck section with benches for people to sit on overlooking the beach area. The addition of properly spaced skid resistant materials to the decking of the ramp section of the large walkover structure would make the deck and the deck extension accessible to handicapped people in wheelchairs. Additional features which could also be added are limited only by the planner's imagination.

The authors would like to thank both Mr. Gill Hill and Mr. William Sensabaugh of the Bureau of Beaches and Shores, Department of Natural Resources, for the ideas and suggestions used in these plans. The authors hope that this publication will lead to the building of more walkover structures in areas where dune systems are threatened by human traffic. The authors also hope to hear any suggestions, comments, or criticism which might be included in a future revision of this publication.

MATERIALS SPECIFICATION SHEET

(1) Wood

All wood to be pressure treated in accordance with American Wood Preservers Association Standard C-2. The preservative used should be a waterborne preservative such as Type B or C or equivalent as covered in Federal Specification TT-W-535 and AWPA Standards P5, C2, and C-14. The type wood to be used depends on the quality of the construction desired. A suitable inexpensive wood for construction would be southern pine. Higher grade and more expensive woods would be the heartwood of Bald Cypress, Redwood, or Eastern Red Cedar. Very expensive but extremely durable and decay resistant woods would be Greenheart or Basra Locus. "Rough cut" lumber can be used on all lumber in the substructure while "dressed" (i.e. surfaced) lumber should be used on the flooring and hand-rails. Further information on the specifications for buying lumber can be found in Reference 2.

(2) Hardware

All bolts and other hardware to be hot dipped galvanized.

(3) Nails

All nails to be galvanized.

GENERAL NOTES

- (1) Bolts in handrails shall have nut end toward post. Countersink so that bolt does not project beyond post. Trim excess of projecting bolts after fastening.
- (2) Use bolts for all connections to posts.
- (3) Do not encase bottoms of pilings in concrete. This would be termed objectionable construction in obtaining a permit from the Bureau of Beaches and Shores.
- (4) Some may find the pitch of the steps (8 on 10) too steep; likewise the ramp slope (20%) is too steep for handicap access (8.33% recommended). The design may be modified accordingly.
- (5) Check with local building officials to make sure the design contained herein, or as modified, conforms to local codes and ordinances.

-
1. Coastal Construction Setback Line by J. A. Purpura and W.M. Sensabaugh, Marine Advisory Bulletin, SUSF-SG-74-002, Florida Cooperative Extension Service, 1974. (Out-of-Print).
 2. Wood Handbook: Wood as an Engineering Material, U.S.D.A., Forest Products Laboratory, 1974.
 3. Timber Design and Construction Handbook, McGraw Hill Publishing Co., 1956.
 4. Wood Engineering, G. Gurfinke1, Southern Forest Products Association, 1973.

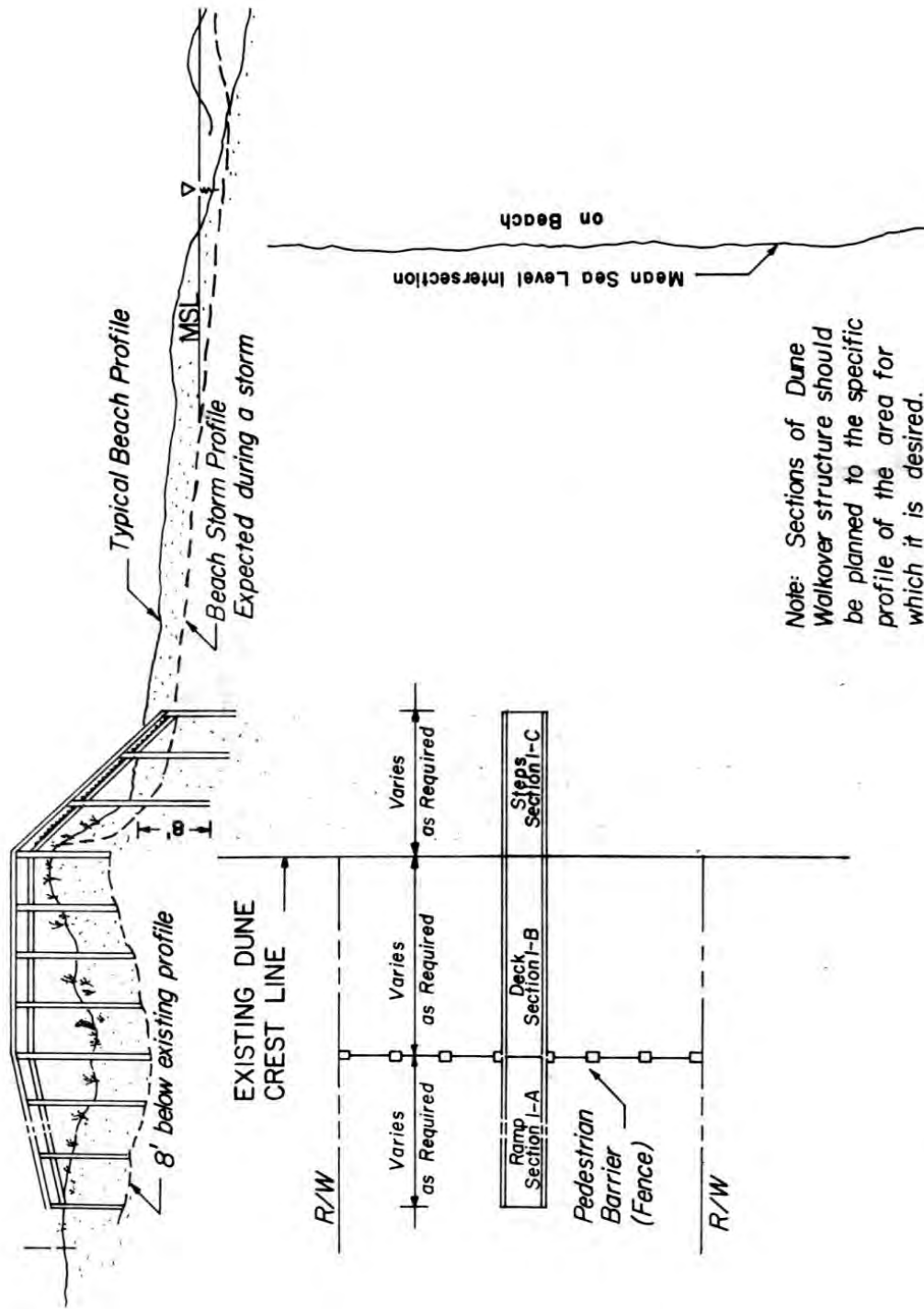

Fig. I TYPICAL PLAN and ELEVATION VIEW

Scale: 1" = 20'

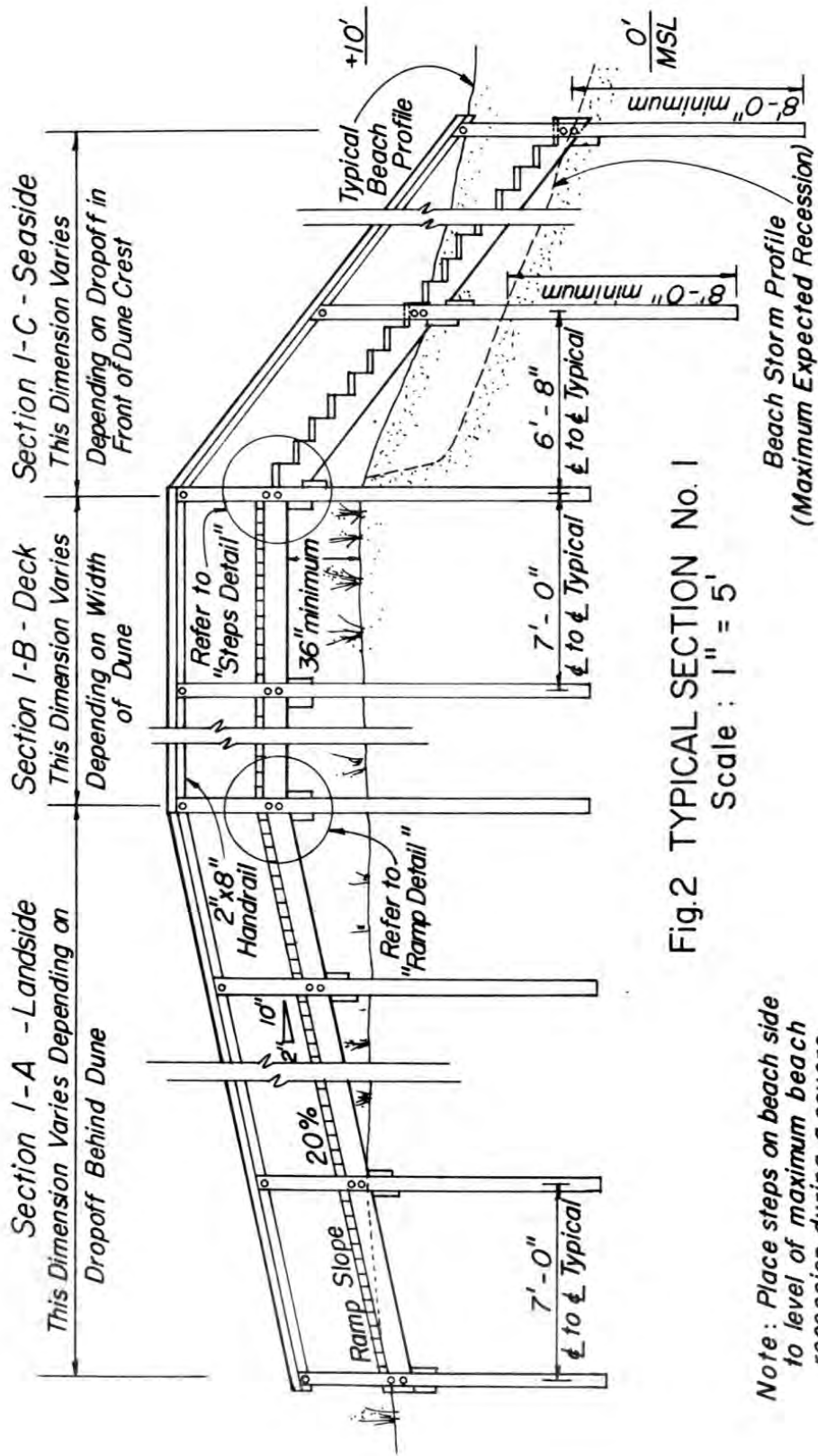

Fig.2 TYPICAL SECTION No. 1
Scale : 1" = 5'

Note : Place steps on beach side to level of maximum beach recession during a severe storm or tropical hurricane

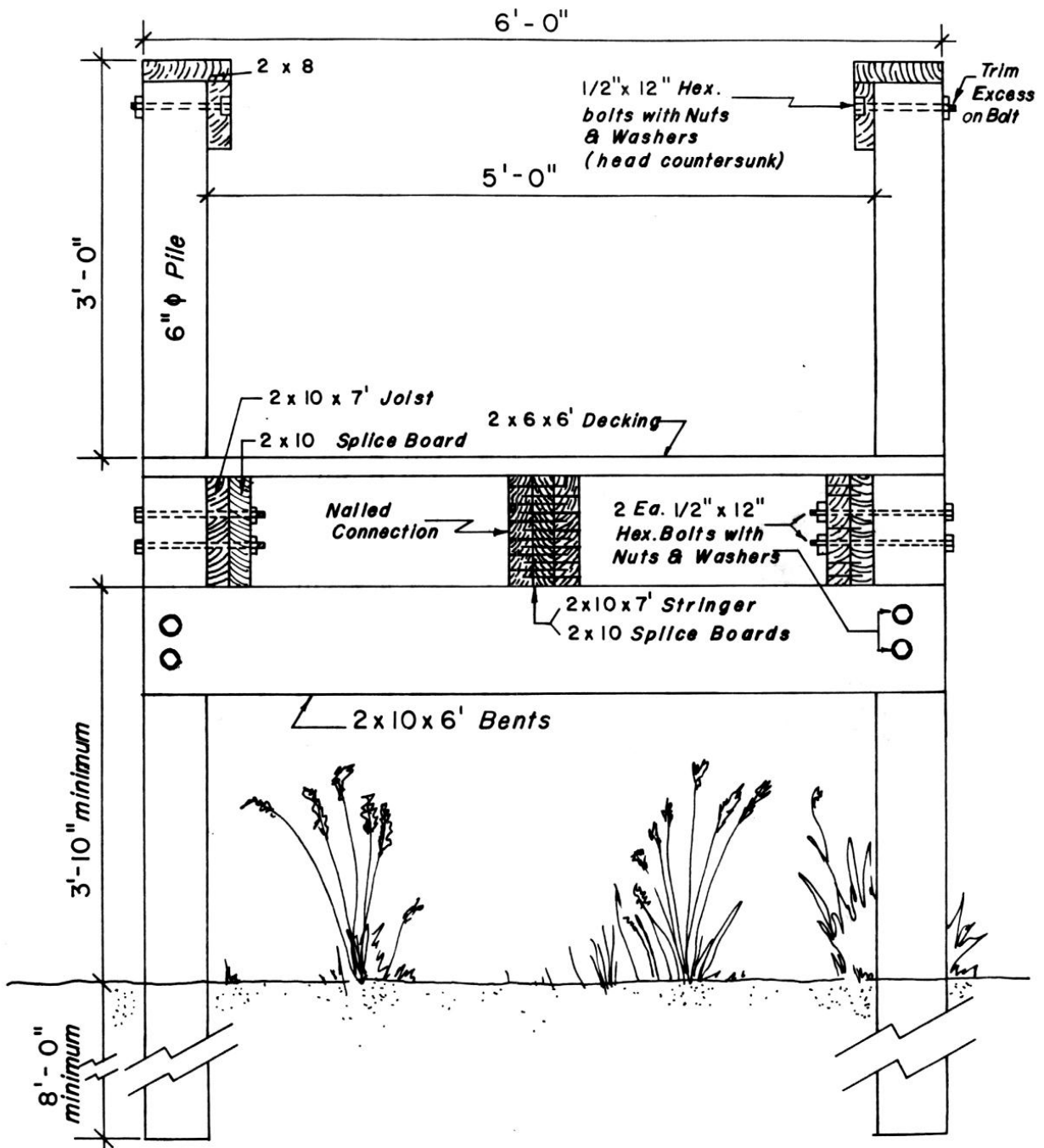

Fig.3 TYPICAL SECTION I-B DECK
Scale: 1" = 1'-0"

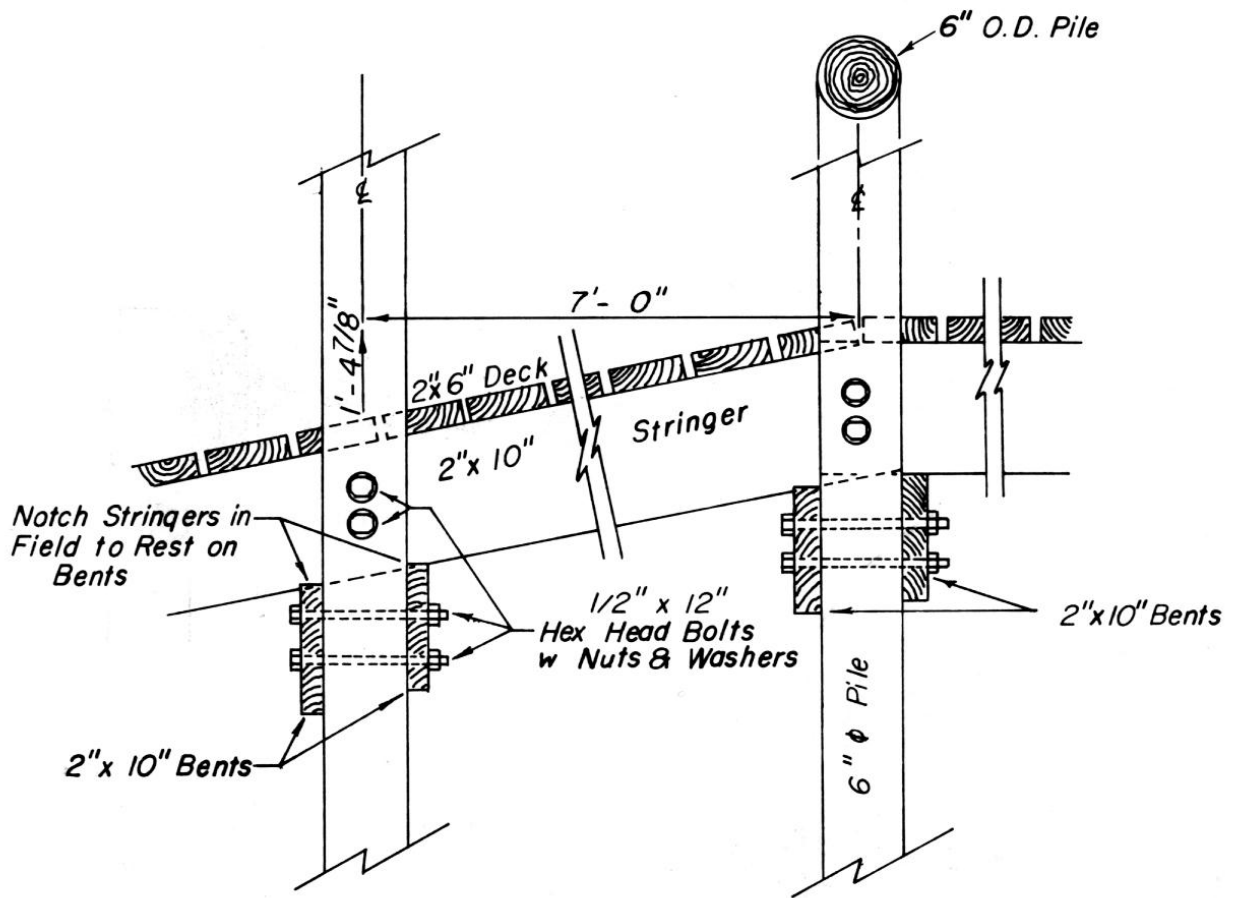

Fig. 4 TYPICAL RAMP DETAIL

Scale: 1" = 1'-0"

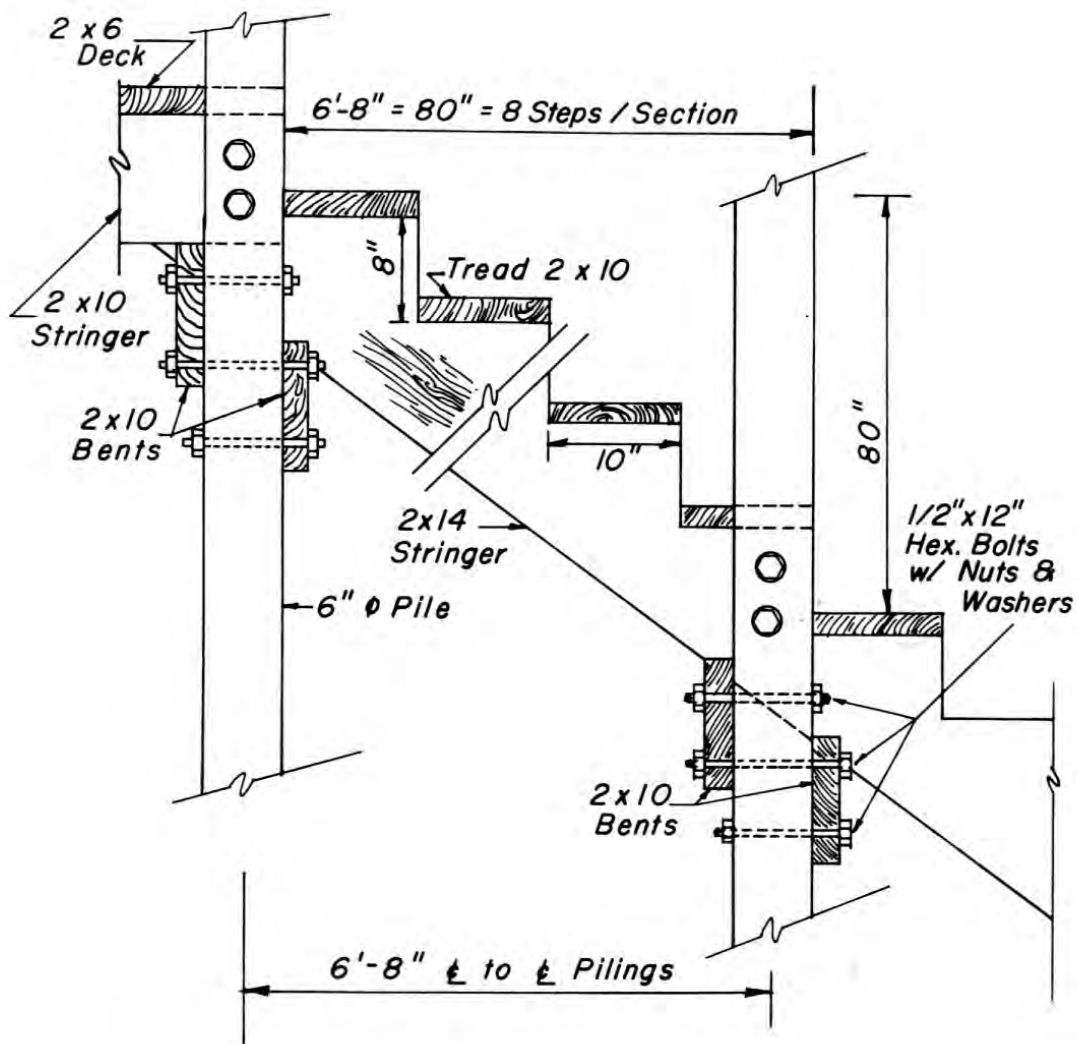
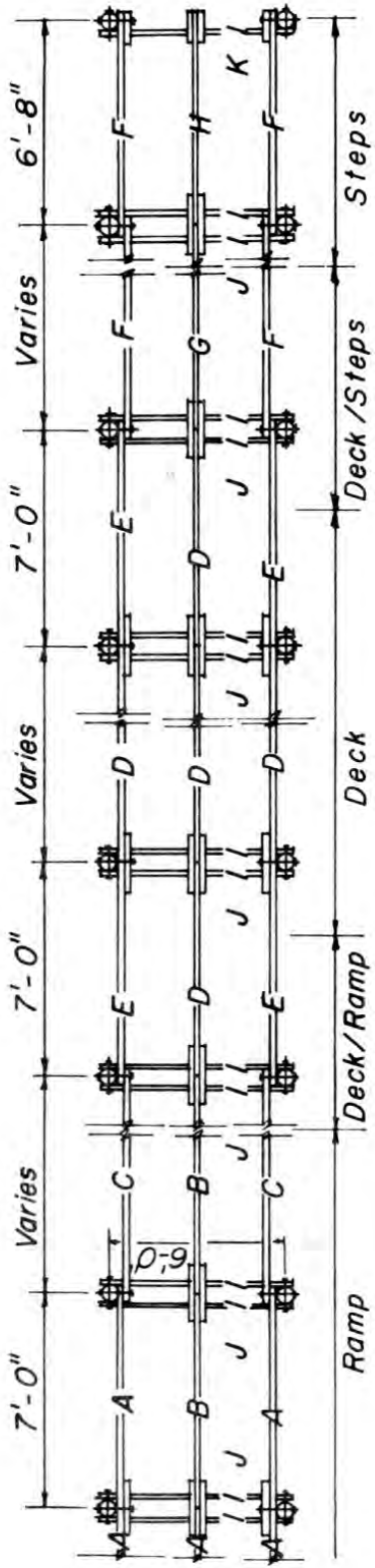

Fig.5 TYPICAL STEPS DETAIL
Scale : 1" = 1'- 0"



Note: All splice blocks to be nailed to stringers to provide both lateral support at joints and bearing support. All pile bolted connections to be 1/2" x 12" hex. bolt with nut and washers.

Stringer Dimensions	
A	2 x 10 x 7'-9"
B	2 x 10 x 7'-6"
C	2 x 10 x 8'-4"
D	2 x 10 x 7'-0"
E	2 x 10 x 7'-3"
F	2 x 14 x 9'-0"
G	2 x 14 x 8'-6"
H	2 x 14 x 8'-9"
Bent Dimension	
I	2 x 10 x 6'-6"
Splice Dimension	
J	2 x 10 x 2'-0"
K	2 x 10 x 1'-6"

Note: Bill of Materials based on ramp length of 21', deck length of 28' and 2 stair sections of 6'-8" each.

Bill of Materials	
Quan.	Item - Description
44	2 x 6 x 20' dressed
9	2 x 8 x 20' dressed
5	2 x 10 x 20' dressed
19	2 x 10 x 20' rough
3	2 x 14 x 20' rough
20	6" Piles @ 16'
100	1/2"x12" hex. bolt with nut and washers

Fig. 6 TYPICAL STRINGER LAYOUT DETAIL
Scale: 1" = 5'-0"

Include as many step sections as necessary to grade from top of dune + 3 feet to base of rear dune.

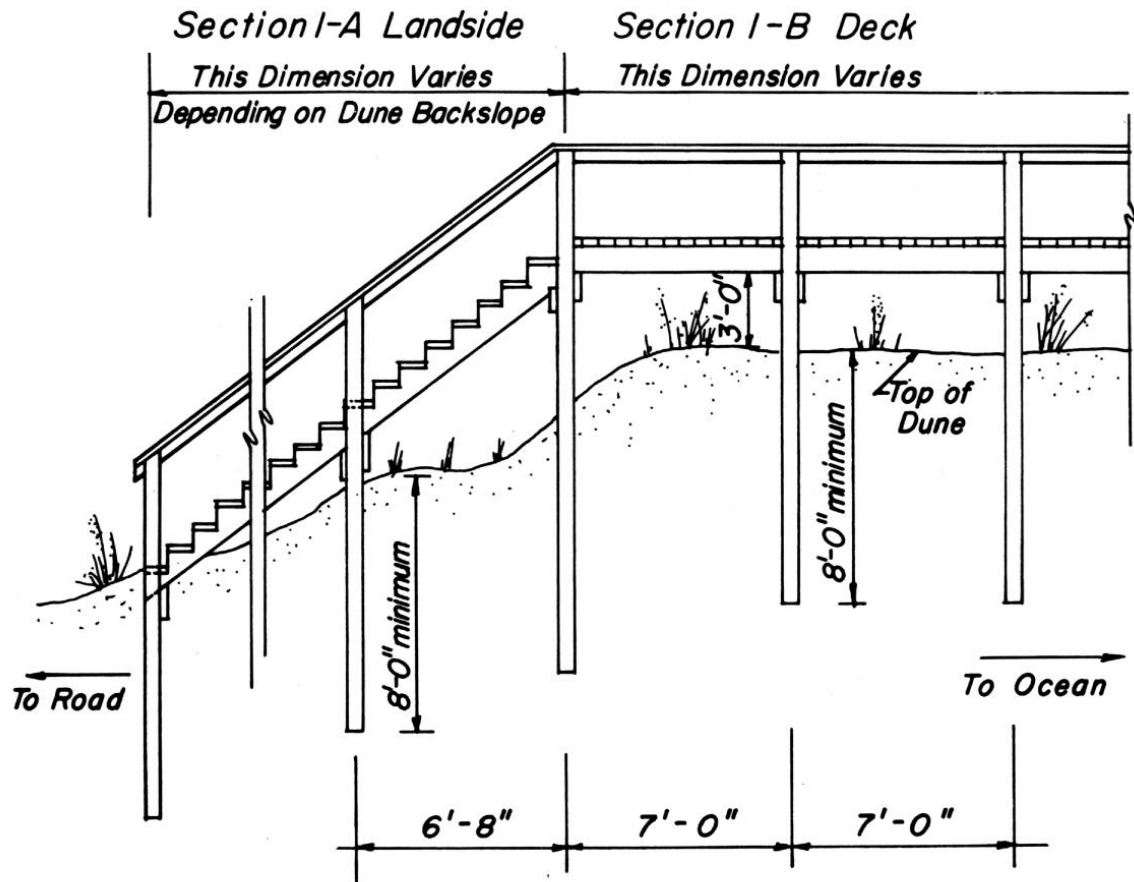

Fig.7 ALTERNATE SECTION No.1

Scale : 1" = 5'-0"

(Refer to details as per Figure 2)

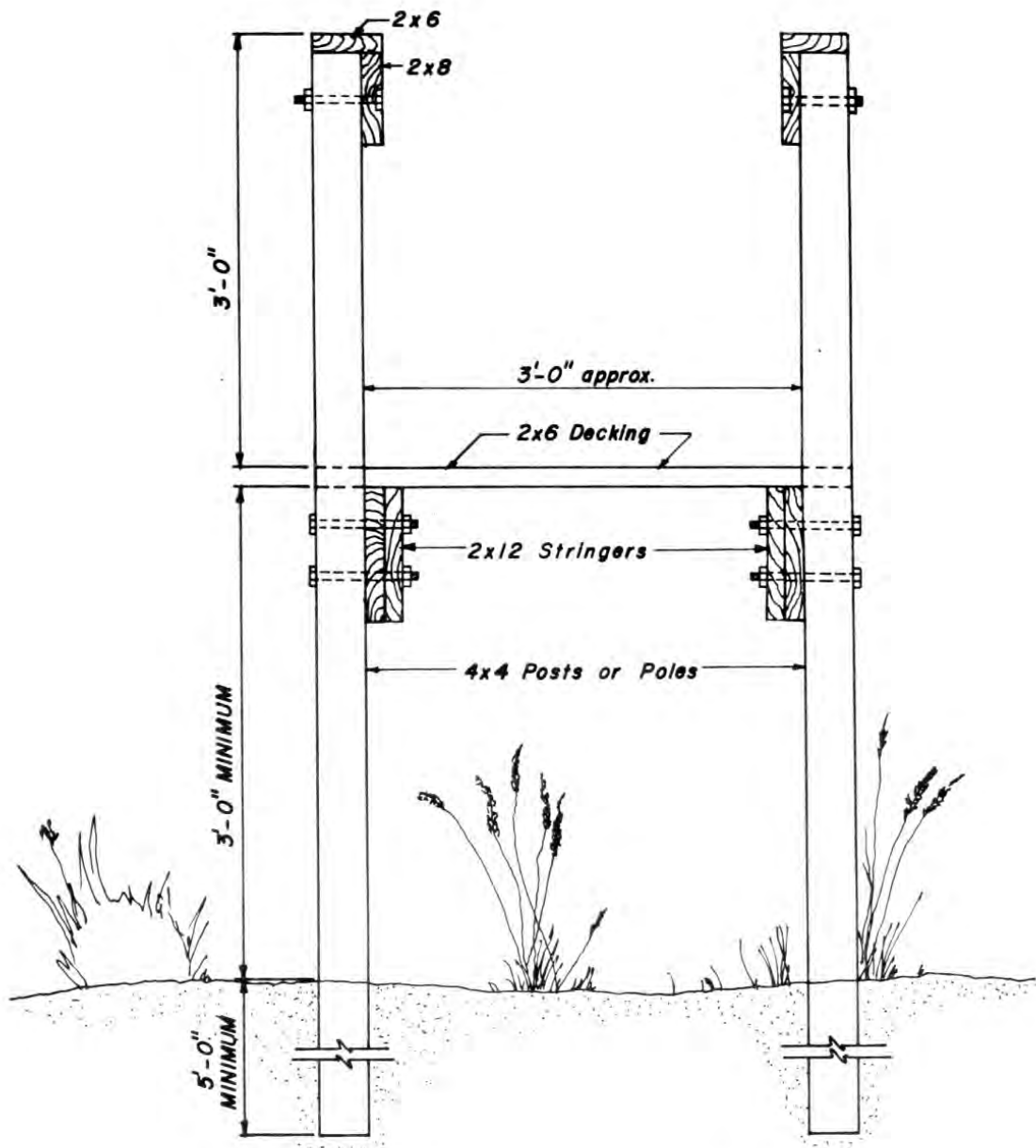
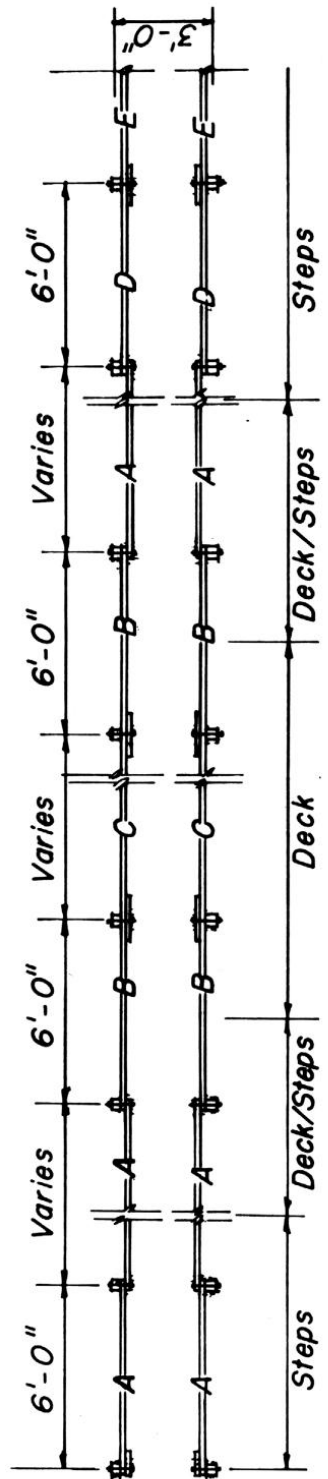

FIG.8 TYPICAL SECTION scale: 1"=1'-0"



STRINGER DIMENSION	
A	2 x 12 x 8' notched for steps
B	2 x 12 x 7'-9"
C	2 x 12 x 6'
D	2 x 12 x 7'-8"
E	2 x 12 x 7'-6"
SPLICE BLOCK DIMENSION	
F	2 x 12 x 1'-6"

BILL OF MATERIALS	
QUANT.	ITEM DESCRIPTION
108'	2x12 Stringers & Splice blocks
16	4' x 4" Posts or Poles
66	1/2x12" Hex bolt w/ nut and washers
36	2x6x20' dressed
28	2x8x20' dressed
4	2x10x20' dressed

Note: All splice blocks to be nailed to stringers to provide both lateral and bearing support at joints. All pile bolted connections to be 1/2" x 12" hex bolt with nut and washers.

Bill of Materials based on 24' deck and step lengths, 6' and 12'.

FIG.9 TYPICAL STRINGER LAYOUT
scale: 1/4" = 5'



Material Durability in Coastal Environments

Wood

Wood Foundations

Wood piles are the most widely used foundation material for elevating coastal residential structures. Southern pine and Douglas fir are the principal wood species used. The piles are placed in the ground by impact driving, water jetting, augering, or some combination of these methods. The piles must be durable in a ground-contact environment at least, and a saltwater immersion environment at most.

Because untreated wood has insufficient decay and infestation resistance for these exposures, piles are almost always preservative pressure-treated to at least the required ground-contact level of resistance. Wood piles must have sufficient strength and straightness to carry the weight of the structure, withstand pile-driving forces at installation, and resist the wind and wave forces acting on the building. Both round tapered timber piles and square cross-section timber piles are commonly used.

Round Tapered Timber Piles

Tapered timber piles with a circular cross section are frequently used in coastal areas. These piles are usually available in longer lengths than square piles, and for lengths more than about 25 feet, it may be necessary to use round tapered piles. The larger round piles have a larger cross-section area, and are stronger and stiffer than 8-inch-square and 10-inch-square section piles. The pile size is specified by the tip or butt circumference and length. The wood species can be specified, and the International Building Code (IBC) and International Residential Code (IRC) provide allowable design stresses for each species. The IBC and IRC refer to the American Society for Testing and Materials (ASTM) D25, *Standard Specification for Round Timber Piles* for physical specifications.

The natural form of a round pile is advantageous for pressure treatment. The sapwood, which is easier to treat than the heartwood, naturally occurs around the tree exterior. The sapwood is exposed to the treatment chemicals and absorbs the chemical to some depth, protecting the largely untreated heartwood. There is usually sufficient sapwood thickness to meet minimum penetration requirements.

Round piles should bear both the wood species and the preservative treatment certification in the form of a stamp, brand, or an attached certificate. The preservative treatment certification should include the American Wood Preservers Association (AWPA) name, the level of treatment, and the type of treatment.

In addition, the straightness of a round tapered pile will affect the accuracy of the pile's location after it has been driven. The straightness is determined by the physical warp properties of sweep and crook. ASTM D25 limits the amount of sweep and crook allowed in a pile.

Poles normally have most of their length above grade. They are usually placed with their smaller end up, so that their tapered section is most effective in resisting axial and bending loads. That is, the axial load increases from the top down in the exposed part, and the thicker section is located near grade, where the bending is maximum. Because of this configuration of the taper, poles cannot be driven, but must be placed in a drilled hole and backfilled. It is unlikely that pole construction would be found in Zone V; pole construction would be possible in Zone A.

Square-Section Timber Piles

In some locations, square section piles are preferred over round piles because of cost, availability, and ease of framing and connecting the structural beams to the piles. The most widely used square piles are the full-sized undressed (rough) 10-inch- and 8-inch-square members. The latter is the minimum size generally approved for use in coastal high hazard areas. The 10-inch-square piles provide a greater axial and bending capacity than 8-inch-square piles, and some local jurisdictions require the larger 10-inch-square piles.

Square-section piles are produced and structurally graded under the “post and timber” lumber grading classification. Like all sawn lumber, square section piles are cut from the log section. Knots in the log will either become edge knots or center knots in the pile, depending on their location. With an edge knot, the wood that was wrapped around the knot has been cut away, so the knot presence weakens the member, especially in bending. This will be reflected in the structural grading of the member.

A square-section pile should bear both the structural grade stamp and the preservative treatment stamp. The lower structural grades allow more and larger knots, as well as more grain slope and warp. The structural grade will be Select Structural, No. 1, or No. 2, in order of decreasing allowable design stresses and stiffness. The preservative treatment stamp should include the AWPA name, the level of treatment, and the type of treatment.

In a sawn square-section member, both sapwood and heartwood can be exposed at the surface. The pressure treatment is absorbed better by the exposed sapwood than by the exposed heartwood; preservative treatment for a square pile can thus be less effective than for a round pile. Ordering Marine Framing of Seawall Grade is one sure method of obtaining a sawn member with no exposed heartwood.

Exposed Wood Beam and Girder Construction

Typically, horizontal wood beams and girders are connected to the top of the wood piles to support the floor framing of the building. These members are often fully or partially exposed to salt spray and precipitation, if not saltwater immersion. Selecting strong and durable materials for these members is critical. These members can be solid sawn timbers, glue-laminated timbers, or built-up sections.

The IBC and IRC require that wood having natural resistance to decay or treated wood be used for beams and girders that are exposed to the weather to prevent moisture or water accumulation on the member

surface or at the joints between members. This requirement is excepted when climatic conditions preclude the need for durability, a condition unlikely at coastal sites. Thus, lumber of natural resistance to decay or lumber that has been preservative-treated should be used for exposed wood beam and girder construction.

Reinforced Concrete

Reinforced concrete foundations (including walls, columns, piers, piles, and pre-stressed elements) may be used in coastal construction, particularly in Zone A and in areas where wood piles cannot be readily driven or in cases where the superstructure will be constructed of concrete, masonry, or a combination of these materials. As an example, in the Florida Keys, concrete foundations are often socketed into a hole augured into the limestone or other bedrock. The concrete mix selection is an important factor in obtaining durable reinforced concrete in many environments.

Reinforced concrete typically has 1.5 or 2 inches of concrete over the steel reinforcement. This concrete cover, specified by the American Concrete Institute (ACI), must resist both salt-laden and freeze-thaw environments. Usually the steel reinforcement is protected from corrosion by the thickness of the concrete cover and the concrete's natural alkalinity. However, in a coastal environment, chloride ions may penetrate the concrete cover, lowering the alkalinity and allowing the steel to corrode. Expansion of the cracks and spalls in the concrete cover allows more salt penetration and corrosion. Thus, concrete mixes for coastal construction must have superior durability properties to resist this action in addition to the required strength properties.

The IBC and IRC require that the durability of a concrete mix subjected to salt intrusion be enhanced by a higher design strength and a lower water-cement ratio. Admixtures for the mix can be chosen to reduce the water-cement ratio for improved durability while maintaining workability. Both the coarse and fine aggregates should be chosen for even gradation and to avoid chemical reactions. If this durable concrete mix is correctly batched, placed, and cured, it is much less likely that the chloride ions will penetrate the concrete cover and cause the steel to corrode.

Usually, standard bare reinforcing steel is used in coastal concrete construction with acceptable results if the concrete mix is selected in accordance with the guidelines given above and the placement is done in accordance with the guidelines in Chapter 16 of the IBC. The reinforcing steel should be free of loose corrosion and salt at the time of placement. Additional durability may be achieved by using epoxy-coated reinforcing steel as designed and specified by a qualified engineer.

Concrete piles are commonly used in coastal mid- to high-rise structures when higher capacity or longer length is required than is available in round wood piles. In some coastal areas, concrete piles are also routinely used for elevated single-family structures. Concrete piles are also used where termite infestation of even preservative-treated wood piles appears likely. Concrete piles are normally precast off site, with either conventional or pre-stressed reinforcement, and are available in a variety of sizes and lengths. The concrete piles used must be suitable in durability characteristics for a coastal environment. Concrete piles cannot easily be used for elevated structures in the higher seismic zones because the seismic requirement for close stirrup confinement reinforcement in a vertical member is difficult to achieve in a concrete pile.

Steel Foundations

Steel piles and sheet piles are commonly used in industrial waterfront construction, but their use has been limited in residential coastal construction. Most steels corrode in a salt-laden environment, and thus require a protective coating. Even the weathering steels are not immune to corrosion. Certain stainless steels under the right conditions are resistant to corrosion, but their cost and other considerations make them unsuitable for foundation elements. Steel piles may be considered where dense soils or gravels make the placement of concrete or wood piles difficult.

Masonry Foundation, Pier, and Wall Construction

As in concrete construction, salt-laden moisture entering reinforced masonry through cracks, defects, or a thin masonry or concrete cover can cause the steel reinforcement to corrode, leading to spalling and loss of strength. Therefore, the choice of masonry unit, mortar, grout, and reinforcement materials is critical.

For concrete masonry units, choosing Type I “moisture controlled” units and keeping them dry in transit and on the job site will minimize shrinkage cracking. For optimum crack control, Type S mortar should be chosen for below-grade applications, and type N mortar for aboveground applications. Horizontal ladder-type joint reinforcement, when used, is placed close to the wall surface in the mortar joint, and is therefore vulnerable to corrosion. This reinforcement, and other metal reinforcement accessories, should be hot-dip galvanized. Distributed horizontal and vertical reinforcement, which should have at least 2 inches of masonry shell and grout cover, may be of plain steel with all loose corrosion and salt removed. The IBC and IRC require, as a minimum, certificates for the materials used in masonry construction indicating compliance with construction documents.

Reinforced masonry and concrete constructed as foundation walls must be supported by either a concrete footing or pile in order to transfer dead, live, and environmental loads to the soil. When a footing is used, the footing must be placed on undisturbed soil with a bearing capacity sufficient to support the building loads with minimal settlement. The footing should be reinforced with sufficient concrete cover as discussed above.



Galvanized Roofing

This resource presents guidelines for the attachment of galvanized metal roofing in Guam, the U.S. Virgin Islands, and other areas of the United States subject to similar wind speeds and coastal hazards. All information presented here is based on specifications and illustrations in the *report Building to Minimize Typhoon Damage: Design Guidelines for Buildings*, prepared by FEMA in response to damage caused by Typhoon Paka in Guam.

Material Specifications

For Guam (and areas subject to similar wind speeds and coastal hazards), use 24-ga aluminum zinc alloy (Galvalume) panels complying with ASTM A 792 Grade 50-B, attached with #14 stainless steel screws with gasketed stainless steel washers.

For the U.S. Virgin Islands and Puerto Rico (and areas subject to similar wind speeds and coastal hazards), use 25-ga panels with all other specifications being the same as above.

Attachment Specifications

See Table 1 and Figures 1 through 3

References

Federal Emergency Management Agency. *Building to Minimize Typhoon Damage: Design Guidelines for Buildings*. July 1998.

Table 1. Complete Load Path Fastener Options

24- ga metal Roofing*	
Option 1: Metal roofing over 3/4"-thick plywood sheathing	
C	#14 screws at 8" o.c. maximum (every third corrugation) in rows 24" o.c. (rows 15" o.c. at ridges and overhangs)
D	#14 screws at 6" o.c. maximum (every second corrugation) in rows 24" o.c. (rows 15" o.c. at ridges and overhangs)
Option 2: Metal roofing over 1/2"-thick plywood sheathing with 1 x 4 battens	
C	#14 screws at 12" o.c. maximum (minimum three screws per sheet) in rows 30" o.c. (rows 18" o.c. at ridges and overhangs)
D	#14 screws at 8" o.c. maximum (every third corrugation) in rows 30" o.c. (rows at 18" o.c. at ridges and overhangs)
Flashing Attachments: See Figures 1 through 3.	
Exterior Grade Plywood Sheathing	
Option 1: 3/4"-thick plywood sheathing attachment to multi-chord roof trusses at 32" o.c.	
C	#14 screws at 10" o.c. maximum (6" o.c. at ridges and overhangs)
D	#14 screws at 7" o.c. maximum (4" o.c. at ridges and overhangs)
Option 2: 1/2"-thick plywood sheathing with 1 x 4 batten attachment to single-chord roof trusses at 16"	
C	#14 screws at 12" o.c. maximum (8" o.c. at ridges and overhangs) with a minimum of two #14 screws per batten to truss
D	#14 screws at 9" o.c. maximum (5" o.c. at ridges and overhangs) with a minimum of two #14 screws per batten to truss
Roof Ridge: To secure roof truss to ridge blocking, use Simpson, or equivalent, A34 Framing Anchor (stagger on opposite sides of blocking for nailing to top chord of truss).	

Notes:

- * Method of attachment used in Guam
- C indicates buildings in exposure B or C
- D indicates buildings in exposure D of influenced by abrupt changes to topography (as defined in ASCE 7)

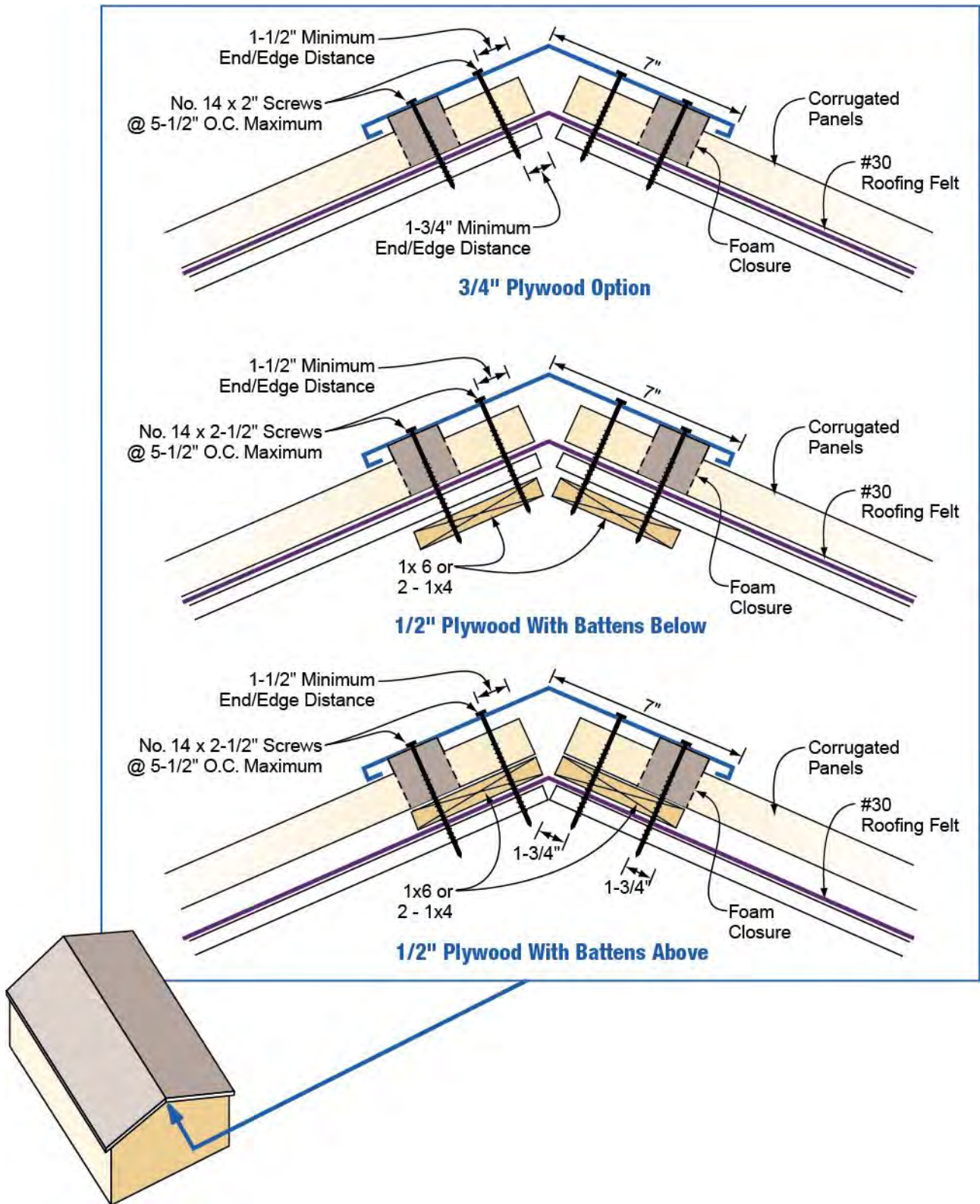

Figure 1. Ridge flashing detail for galvanized metal roofing.

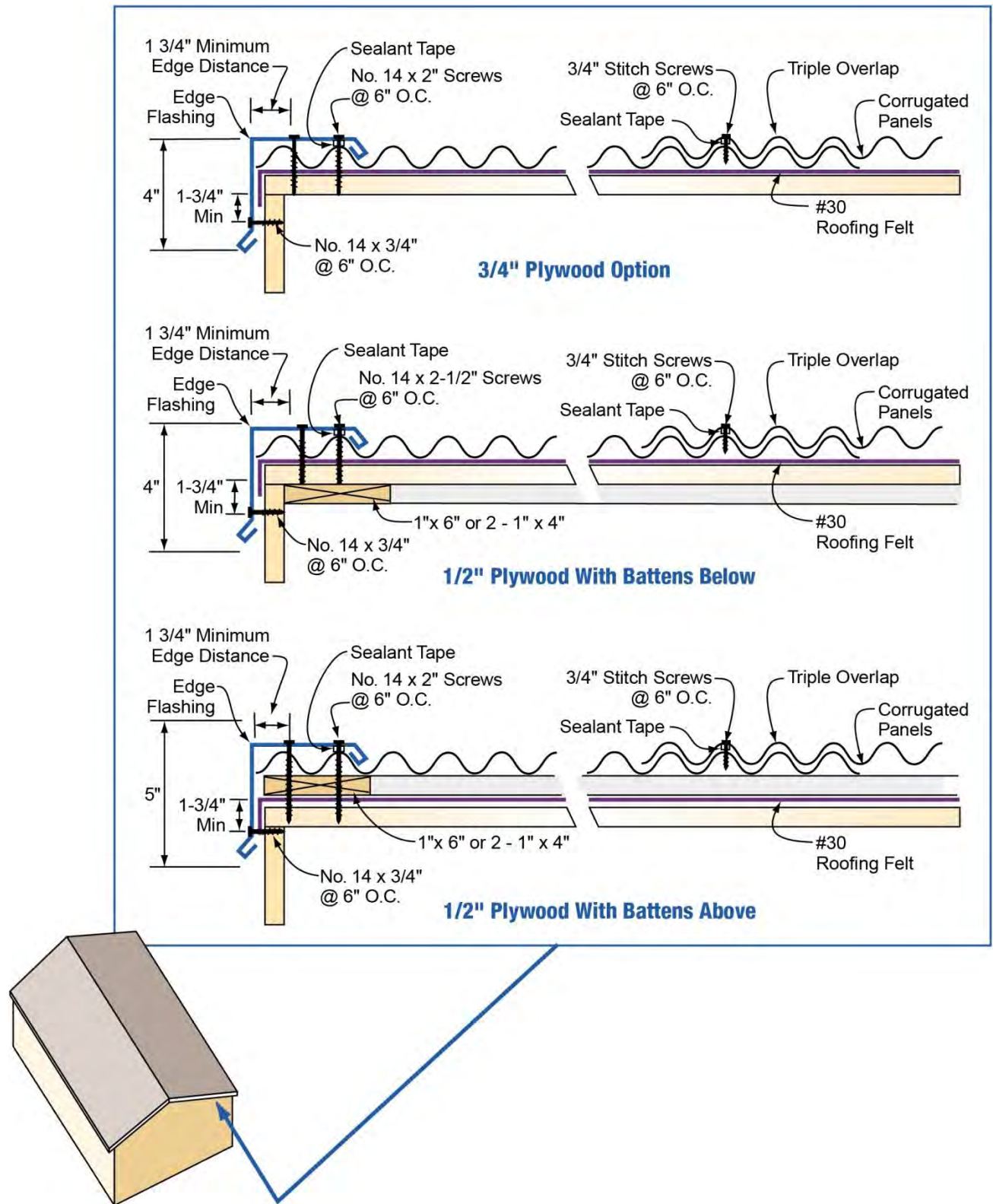

Figure 2. Eave flashing detail for galvanized metal roofing.

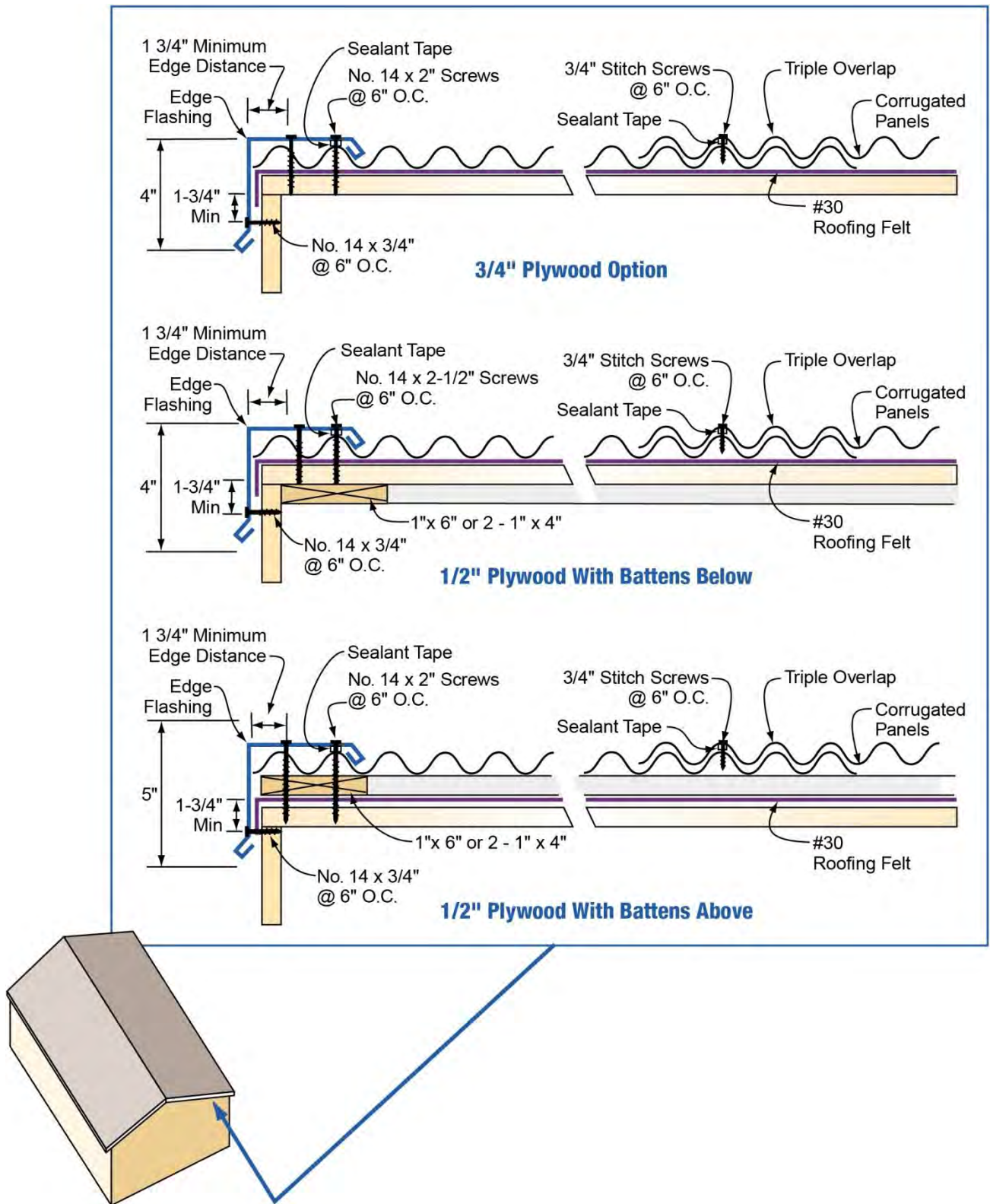

Figure 3. Rake flashing detail for galvanized metal roofing.



Swimming Pool Design Guidance

This resource contains copies of the following two articles, which appeared in the Winter 1996 and Winter 1997 issues of the *Journal of Coastal Research* (JCR):

Scour Impact of Coastal Swimming Pools on Beach Systems, by Soronnadi Nnaji, Nur Yazdani, and Michelle Rambo-Roddenberry (JCR, Winter 1996)

Conceptual Breakaway Swimming Pool Design for Coastal Areas, by Nur Yazdani, Soronnadi Nnaji, and Michelle Rambo-Roddenberry (JCR, Winter 1997)

The research work reported in these papers was funded by a grant from FEMA and the Florida Department of Environmental Protection (FDEP).

Scour Impact of Coastal Swimming Pools on Beach Systems

Soronnadi Nnaji†, Nur Yazdani† and Michelle Rambo-Rodenberry‡

†Florida A&M University/Florida
State University
College of Engineering
Tallahassee, FL 32316, U.S.A.

‡Virginia Polytechnic Institute
and State University
Blacksburg, VA 24061, U.S.A.



ABSTRACT

NNAJI, S.; YAZDANI, N., RAMBO-RODENBERRY, M., 1996. Scour impact of coastal swimming pools on beach systems. *Journal of Coastal Research*, 12(1), 186-191. Fort Lauderdale (Florida), ISSN 0749-0208.

Swimming pools have become an integral part of habitable coastal construction. These pools frequently increase the turbulence of floodwater during a tropical storm or hurricane. This results in an increase in the scour potential under and around swimming pools. This paper demonstrates that a suitable scour model for seawalls from literature is applicable to coastal swimming pools, including over-topping and corner effects. The model predicts substantial scour around pools for typical storm waves and water levels. Optimum sizing and siting for coastal swimming pools are also discussed.

ADDITIONAL INDEX WORDS: *scour, swimming pools, dune systems, erosion, flooding.*

INTRODUCTION

The State of Florida has an extensive tidal shoreline. In recent years, this shoreline has been subjected to rapid development and construction due to a massive population influx. Swimming pools have become essential accessories attached to habitable coastal construction in terms of property value and the tourism industry in Florida. Virtually all of these pools are situated seaward of the habitable structure.

The Federal Emergency Management Agency (FEMA) oversees the construction of all structures (including pools) in the Coastal High Hazard Areas (V-zones) in order for these structures to be insured under the National Flood Insurance Program (NFIP). These requirements are contained in 44CFR Section 60.3 which states that all new construction and substantial improvements in Zones V1-V30, VE, and V shall have the area below the lowest floor level, either free of obstruction or constructed with non-supporting breakaway walls or similar structures.

If a swimming pool is placed below the level of a coastal building, but above natural grade, it may behave as an obstruction to the free flow of flood water. A large object, such as a swimming pool, placed above the natural grade may increase the

turbulence of the floodwater, resulting in an increase in the scour potential under and around pools and around the pile supports.

The objective of this paper was to formulate a wave scour model around coastal swimming pools. Optimum siting, sizing, and design conditions for coastal pools need to be considered in order to minimize unwanted scour effect on beach/dune systems and adjacent structures. Siting aspects include the encroachment, orientation and elevation of pools, while sizing aspects include the shape and depth of pools.

The effect of a swimming pool type massive structure on coastal topography during a storm has been apparent over the years; however, documentation of this effect has started only recently. No basic research has been performed to attempt to understand this effect and to determine methods to minimize such costly damage.

LITERATURE REVIEW

Various studies have been performed on scour around coastal structures, such as piers, abutments, piles, pipelines, and seawalls during extreme flooding. Several reports on scour evaluation and methods for predicting scour around coastal structures were reviewed, including: EADIE and HERBICH (1987), FROEHLICH (unknown), HERBICH (1968, 1981), IBRAHIM and NALLURI (un-

94201 received 19 September 1994; accepted in revision 25 February 1995.

known), JAIN and FISCHER (1979), KADIB (1963), KAWATA and TSUCHIYA (1988), KHANBILVARDI *et al.* (1988), BREUSERS (1972), HANCU (1971), FOTHERBY (1992), FOWLER (1992, 1993), SHEPARD and NIEDORODA (1990), RANCE (1980), and RICHARDSON (1993). However, no previous or continuing studies were found which address scour around coastal swimming pools. Additional studies have been performed in the Netherlands, U.K., Japan and Norway. Most previous studies dealt with scour around other types of coastal structures. The applicability of these models to coastal swimming pools is questionable, especially because of the dissimilarity of geometric parameters.

The authors were seeking a scour prediction model that included most of the pertinent variables associated with coastal swimming pools and yielded reasonable results. A model developed by HERBICH (1984) for ultimate scour depth at seawalls was found to be one such model. This model was developed using Prandtl's boundary layer theory along a flat plate, from the definition of stream function and from the continuity equation between a section before scouring and a section when the ultimate scour is reached. POWELL (1987) cites the limitations of the Herbich equation are as follows: (1) the equation was only validated by a few model tests, which were affected by scaling errors; (2) the equation predicts the scour averaged over a distance, rather than the depth of toe scour; and (3) the equation was derived for non-breaking waves and flat sea beds.

DEVELOPMENT OF SCOUR MODEL

Pertinent variables for predicting scour around coastal swimming pools (based on literature review) may include the following: wave height, median sediment diameter, sediment density, fluid density, shape factor, velocity of flow, wave length (L), wave period (T), time (t), acceleration due to gravity (g), and structure height. A scour model for coastal swimming pools was developed in this paper based on the scour equation from HERBICH (1984). The Herbich equation for ultimate scour depth at seawalls is as follows:

$$S = (d - A/2) \left[(1 - C_r)u. \left\{ \frac{3}{4} C_D \rho \frac{\cot \theta}{d_{50}(\gamma_s - \gamma)} \right\}^{1/2} - 1 \right] \quad (1)$$

in which d = depth to still water level (SWL) at the wall, A = wave height at the wall = $H_I + H_R$ (incident wave height + reflected wave height), C_r = reflection coefficient = H_r/H_I , $u.$ = local horizontal velocity parallel to the bottom, C_D = coefficient of drag, ρ = density of water, θ = angle of repose of the sediment, d_{50} = mean diameter of the sediment, γ_s = specific weight of the sediment, and γ = specific weight of the water.

From DAS (1990), sand grain diameter ranges from 0.075 to 4.75 mm (0.003 to 0.19 inch) (Unified Soil Classification System), and the specific gravity of light colored sand may be assumed to be about 2.65. The authors assumed the median sand grain diameter to be 0.5 mm (0.02 inch). From HERBICH *et al.* (1984), the coefficient of drag depends on the Reynolds number and the shape factor of the sediment. The authors assumed a value of 0.7 for the coefficient of drag for coastal swimming pools in the turbulent zone. This value was assumed from HERBICH *et al.* (1984) for an average sediment shape factor of 0.7. The local horizontal velocity parallel to the bottom, $u.$, depends on the water depth to wave length ratio (d/L). This ratio determines whether the condition is shallow water ($d/L < 1/25$), transitional water ($1/25 < d/L < 1/2$), or deep water ($d/L > 1/2$). The following expression for $u.$ for shallow water conditions is applicable for coastal swimming pools:

$$u. = H/2(g/d)^{1/2} \cos \theta_p \quad (2)$$

in which H = wave height, d = water depth to SWL, and θ_p = phase angle. The phase angle θ_p can be expressed as $2\pi x/L - 2\pi t/T$, where x is the horizontal distance travelled by the wave. The wave length can be found by the following equation for shallow water:

$$L = T(gd)^{1/2} \quad (3)$$

The angle of repose of the sediment is found from the relationship of components in Figure 1 (HERBICH, 1984). In this figure, the drag force F_D and the weight of the particle W may be expressed as:

$$F_D = C_D \rho (u.^2/2) (\pi d_{50}^2/4) \quad (4)$$

$$W = \pi d_{50}^3 (\gamma_s - \gamma) / 6 \quad (5)$$

From Figure 1,

$$\theta = \tan^{-1} [0.75 C_D \rho u.^2 / d_{50} (\gamma_s - \gamma)] \quad (6)$$

From the Shore Protection Manual (U.S. Army

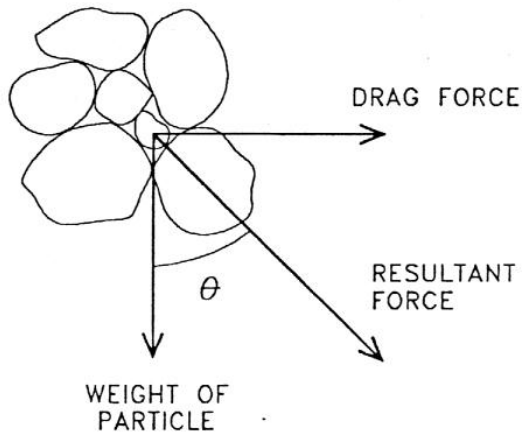

Figure 1. Initiation of sand particle movement.

1984), the reflection coefficient C_r , is the ratio of the reflected wave height to the incident wave height. For perfect reflection, where the reflected wave height equals the incident wave height, C_r is unity. This coefficient depends on the geometry and roughness of the reflecting wall and possibly on the wave steepness and the "wave height-to-water depth" ratio. C_r should be taken as 1.0 for walls; a value less than 0.9 should not be used for design purposes.

Scour around swimming pools may differ from scour around seawalls because of two reasons. A swimming pool has corners, while a seawall is assumed to have an infinite length. Also, in the Herbich equation (Equation 1), there is no consideration for overtopping by a wave. As shown in Figure 2, overtopping is very probable for coastal swimming pools in case of an extreme storm.

From physical modeling by RANCE (1980) for large objects, scour depth at the corners was as much as 18 times the scour depth in front of the wall. The authors believe that this ratio may be large because the sand that is removed from the front of the wall is replaced by the sand removed from the corners. The scouring effect at the corners may cause an increase in the scour depth at the corners and a decrease in the scour depth in front of the wall. Thus, the authors believe that the scour depth predicted by Equation 1 may be a good representation of the average scour depth along the wall for swimming pools.

As for the overtopping condition, for vertical walls, the least wave attack behind the wall and the largest scour depth in front of the wall were

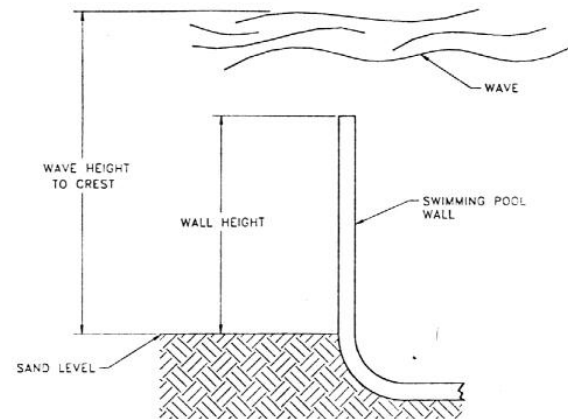

Figure 2. Overtopping of pool wall by wave.

observed to occur when the top elevation of the wall was one wave height above the SWL (KADIB 1963). The largest wave attack on the area behind the wall and the smallest scour in front of the wall were observed when the top elevation of the wall was at a half wave height below the SWL. From these observations, it may be inferred that maximum scour occurs before overtopping in general. Thus, the authors assumed that the scour depth predicted by Equation 1, even if overtopping occurs, will provide an approximate conservative prediction for the average scour depth along the length of a coastal swimming pool wall.

Because the Herbich equation was derived for non-breaking waves, the predicted scour depth will probably be smaller than the actual scour depth under breaking wave conditions. This is due to the fact that breaking waves cause greater scour than non-breaking waves.

Predicted scour depths from Equation 1 for a depth to SWL of 1.8 m (6 ft) and various values of the coefficient of reflection is presented in Figure 3. Because C_r is to be taken as 1.0 for design purposes, a graph of scour depth versus wave height for several values of depth to SWL is presented in Figure 4 for C_r equal to 1.0. In these figures, the negative sign represents scour, or sand being removed from the front of the wall. The general trend is the decrease in scour depth with the increase in wave height for a given depth to SWL. Also, for a given wave height, the scour depth increases, with an increase in depth to SWL. As the reflection coefficient increases, the scour depth increases until H/d (wave height/water

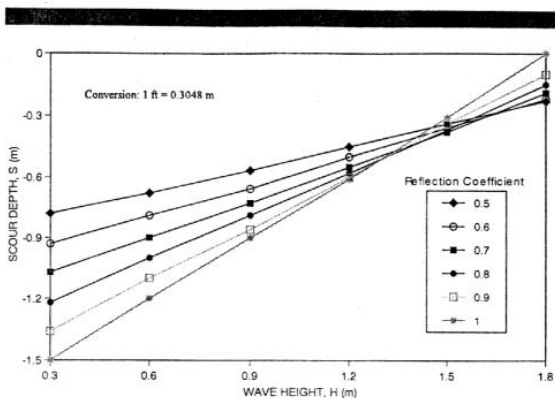

Figure 3. Scour depth vs. wave height, for depth to still water level of 1.8 m.

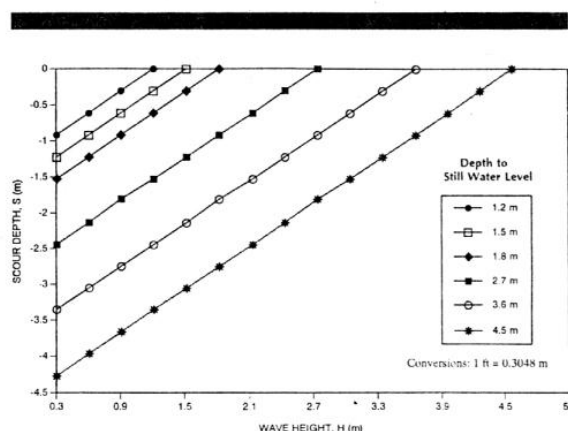

Figure 4. Scour depth vs. wave height, for reflection coefficient (C.).

depth to SWL) is approximately 0.7, which is generally accepted as the initiation point for breaking waves (Figure 3). It is interesting to note that the curves for the reflection coefficient cross at the approximate value for H/d of 0.7, and the scour depth begins to decrease with an increase in reflection coefficient. It should be noted that beyond the approximate value of 0.7 for H/d , Equation 1 may no longer be valid, because it was developed for nonbreaking waves and not for breaking waves.

OPTIMUM SITING AND SIZING CONDITIONS

The variables in Equation 1 for scour prediction are: wave period, wave height, depth to SWL, and reflection coefficient. The first three variables are site specific to a particular pool; therefore, general conclusions cannot be made based on these variables. Thus, the authors were not able to recommend general optimum siting/sizing aspects for pools based on this equation. Other sources were utilized to make general conclusions for optimum siting/sizing aspects.

RANCE (1980) studied scour around large objects through physical modeling. His observations are reproduced in Table 1. The following conclusions may be made for coastal swimming pools based on Rance's observations: (1) a round swimming pool is expected to experience approximately half the scour around a square pool; and (2) rotating a square pool so that the wave angle of attack is 45 degrees causes approximately 40% more scour than a pool with a zero degree angle of attack.

The following conclusions were made by Ri-

CHARDSON (1993) for riverine piers: (1) an increase in pier width causes an increase in scour depth; (2) with a zero degree angle of attack, pier length does not significantly affect local scour depth; if the pier is skewed, doubling the pier length increases scour depth by 33%.

The following general conclusions about the effect of siting/sizing aspects on scour around coastal swimming pools are based on Richardson's observations: (1) a small angle of attack causes the least scour; and (2) it is best to place the side of the pool with the smaller dimension perpendicular to the flow; for example, placing the longer side perpendicular to the flow causes 2.5 times the scour as placing the shorter side perpendicular to the flow for a length to width ratio of 4; and (3) a smaller length to width ratio causes less scour.

CONCLUSIONS

Scour around and under coastal structures such as piers, abutments, piles, pipelines and seawalls has been extensively studied in the U.S.A. and in countries such as the Netherlands, the U.K., Ja-

Table 1. Scour around objects with diameter larger than a tenth of a wavelength (RANCE, 1980).

	Shape	Maximum Scour Depth	Horizontal Extent of Scour
Flow Direction →	○	0.064 Dp*	0.75 Dp
	◇	0.180 Dp	1.00 Dp
	□	0.128 Dp	0.75 Dp

*Dp = equivalent diameter of structure

pan and Norway. The applicability of these models to a coastal swimming pool type structure has not been investigated. The Herbich equation (1984) for ultimate scour depth at seawalls contains most of the pertinent variables for scour around coastal swimming pools. This equation does not include the effects of a wave overtopping the pool wall or the effects of the corners of the wall. The extent that these two parameters affect around coastal swimming pools is expected to be negligible. The Herbich equation is not intended for use with elevated pools. A round swimming pool is likely to experience approximately half the scour experienced by a square pool. The angle of attack of the wave directly affects scour around coastal pools. A zero degree angle of attack is likely to result in least scour. Placing the smaller dimension of a rectangular pool parallel to the shore (or perpendicular to the wave) is beneficial in controlling scour around coastal pools. The conclusions made in this study are strictly based on theoretical studies and scour models for non-swimming pool structures. Physical modeling of coastal swimming pools is needed to validate pool scour models reported in this paper.

ACKNOWLEDGEMENT

The research work reported in this paper was funded by a grant from the Federal Emergency Management Agency (FEMA) and the Florida Department of Environmental Protection (FDEP). Special thanks are due to Clifford Oliver from FEMA, Alfred Deveraux from FDEP, and Paden Woodruff from FDEP for their valuable suggestions. The authors are grateful to Cynthia Mulkey for typing the manuscript and to Moorily Suppiah for the graphics work.

LITERATURE CITED

- BREUSERS, H.N.C., 1972. Local Scour Near Offshore Structures. *Offshore Hydrodynamics Symposium, Proceedings, Oosterveld, M.W.C., Wageningen, Netherlands*, August 25-26.
- DAS, B.M., 1990. *Principles of Geotechnical Engineering*. 2nd ed., Boston: PWS-Kent.
- EADIE, R.W. and HERBICH, J.B., 1987. Scour About a Single, Cylindrical Pile Due to Combined Random Waves and a Current. *Proceedings, Twentieth Coastal Engineering Conference*, V.3.
- FOTHERBY, L.M., 1992. *Footings, Mats, Grout Bags, and Tetrapods: Protection Methods Against Local Scour at Bridge Piers*. Boulder, Colorado State University.
- FOWLER, J.E., 1992. Scour problems and methods for prediction of maximum scour at vertical seawalls. *Coastal Engineering Research Center, Technical Report CERC-92-16*, December 1992.
- FOWLER, J.E., 1993. Coastal scour problems and methods for prediction of maximum scour. *Coastal Engineering Research Center, Technical Report CERC-93-8*, May 1993.
- FROEHLICH, D.C., Analysis of onsite measurements of scour at piers. *Journal of Hydraulic Engineering*, (source unknown).
- HANCU, D.I.S., 1971. Sur le Calcul des Affouillements Lacaux dans la Zone des Piles du Pont. *Intern. Assoc. for Hydraulic Research and Its Impact on the Environment*, V.3 paper C36.
- HERBICH, J.B. and KO, S.C., 1968. Scour of sand beaches in front of seawalls. *Proceedings, Eleventh Coastal Engineering Conference*.
- HERBICH, J.B., 1981. Scour around pipelines and other objects. *Offshore Pipeline Design Elements*, Chap.3, 1981.
- HERBICH, J.B.; SCHILLER, R.E.; DUNLAP, W.A., and WATANABE, R.K., 1984. *Seafloor Scour: Design Guidelines for Ocean-Found Structures*. New York and Basel, Switz: Marcel Dekker
- IBRAHIM, A. and NALLURI, C., *Scour Prediction Around Marine Pipelines*, (source unknown).
- JAIN, S.C. and FISCHER, E.E., 1979. Scour around circular bridge piers at high froude numbers. *National Technical Information Service, Document No. PB 80-139322*, U.S. Dept. of Commerce.
- KADIB, A., 1963. Beach profiles as affected by vertical walls. *Beach Erosion Board Technical Memo No. 134*.
- KAWATA, Y. and TSUCHIYA, Y., 1988. Local scour around cylindrical piles due to wave and currents combined. *Proceedings, Twenty-first Coastal Engineering Conference, Spain*, V.2, Chap. 97.
- KHANBILVARDI, R.M.; AKHTAR, M.W., and ROGOWSKI, A.S., 1988. Local scour around cylindrical objects. *Water Resources Bulletin*, American Water Resources Association, 24(4).
- POWELL, K.A., 1987. Toe scour at sea walls subject to wave action. *Hydraulics Research, Wallingford, Report SR 119*.
- RANCE, P.J., 1980. The potential for scour around large objects. *Scour Prevention Techniques Around Offshore Structures*. The Society for Underwater Technology, Seminar in London, 16 December, 1980.
- RICHARDSON, D., 1990. Evaluating scour at bridges. *Federal Highway Administration, Report No. FHWA-IP-90-017*, HEC 18.
- SHEPPARD, D.M. and NIEDORODA, A.W., 1990. *Local Structure Induced Sediment Scour*. Department of Coastal and Oceanographic Engineering, University of Florida.
- U.S. ARMY, 1984. *Shore Protection Manual*. Washington: Coastal Engineering Research Center, Department of the Army, Volume II, 4th ed.

APPENDIX II. NOTATION

The following symbols are used in this paper:

- A = wave height at the wall;
 C_D = coefficient of drag;
 C_r = reflection coefficient;
d = depth to still water level;
 d_{50} = mean diameter of the sediment;

F_D = drag force;	x = horizontal distance traveled by the wave;
g = acceleration due to gravity;	θ = specific weight of the water;
H_I = incident wave height;	γ_s = specific weight of the sediment;
H_r = reflected wave height;	θ = angle of repose of the sediment;
L = wave length;	θ_p = phase angle;
S = ultimate scour depth;	ρ = density of water
T = wave period;	
$u.$ = local horizontal velocity parallel to the bottom;	

CONCEPTUAL BREAKAWAY SWIMMING POOL DESIGN FOR COASTAL AREAS

Nur Yazdani, Soronnadi Nnaji and Michelle Rambo-Rodenberry

Department of Civil Engineering
Florida A&M University/Florida State University
College of Engineering
Tallahassee, Fla. 32316-2175

Department of Engineering
Florida A&M University/Florida State University
College of Engineering
Tallahassee, Fla. 32316-2175

Virginia Polytechnic Institute and State University
Blacksburg, Virginia 24061

ABSTRACT

Swimming pools have become an essential attachment to most habitable coastal construction such as hotels, condominiums and single family residences. A large swimming pool type structure may obstruct the free flow of flood water and increase the turbulence. This in turn may increase the scour potential and the wave/debris action on the building and foundation. A conceptual breakaway concrete swimming pool design is described herein. It is demonstrated that this pool will withstand everyday factored water/soil loading, but will collapse and breakaway under extreme wave action, thereby minimizing the detrimental effects of a solid pool.

ADDITIONAL INDEX WORDS: Key-words: Breakaway, swimming pool, scour, coastal construction.

INTRODUCTION

The State of Florida has an extensive tidal shoreline. In recent years, this shoreline has been subjected to rapid development and construction due to a massive population influx. Swimming pools have become essential accessories attached to habitable coastal construction in terms of property value and the tourism industry in Florida. Virtually all of these pools are situated seaward of the habitable structures.

The Federal Emergency Management Agency (FEMA) oversees the construction of all structures (including pools) in the Coastal High Hazard Areas (V-zones) in order for these structures to be insured under the National Flood Insurance Program (NFIP). These requirements are contained in 44CFR Section 60.3 which states that all new construction and substantial improvements in Zones V1-V30, VE, and V shall have the area below the lowest floor level either free of obstruction, or constructed with non-supporting breakaway walls or similar structures.

If a swimming pool is placed below the level of a coastal building, but above natural grade, it may behave as an obstruction to the free flow of flood water. A large object, such as a swimming pool, placed above the natural grade may increase the turbulence of the floodwater, resulting in an increase in the scour potential under and around pools, and around the pile supports. The extra turbulence created by the presence of the pool structure may also cause increased wave and debris action on the elevated portion of the building or other adjacent structures and foundations.

Coastal swimming pools should withstand everyday water and soil loads with an adequate factor of safety, but should collapse and break away in case of a 100-year flood event without acting as an obstruction to the flow of floodwater. If pools located below the base flood elevation in V-

zones were designed to disintegrate and not cause water build-up or act as debris on upland structures or their piles during a specified storm, the detrimental effect on the beach/dune system or adjacent structures would be drastically reduced. Swimming pools designed to be frangible will help preserve the integrity of the beach/dune system and other structures in extreme flooding conditions.

The effect of a swimming pool type massive structure on coastal topography during a storm has been apparent over the years; however, documentation of this effect has started only recently. No basic research has been performed on understanding this effect, or on ways to minimize such costly damage.

DATA ON EXISTING POOLS

The Florida Department of Environmental Protection (FDEP) is responsible for permitting of coastal construction in the coastal zone. Permitting files from FDEP were searched to investigate common scenarios for swimming pools on the Florida coast. Important variables that were recorded include: the shape, dimensions, orientation to the Coastal Construction Control Line (CCCL), location relative to CCCL, maximum depth, 100 year storm surge, distance above or below the sand level and material used. Pool data for 23 swimming pools located in coastal regions of Florida are presented in Table 1. Data was gathered from the FDEP permitting files for the last four years.

From Table 1, it is observed that only one of the pools is fiberglass; the remainder are concrete or gunite. The distribution of the shapes of the pools is: 70% rectangular, 13% kidney, 4% oval, 9% odd and 4% round. The average largest dimension is 34.4 feet; the average smallest dimension is 17.4 feet.

BREAKAWAY POOL LAYOUT

To force breakaway mechanism in a coastal swimming pool under an extreme storm, joints at 2 ft. on center in the top 3 ft. of the pool walls will be assumed. The ACI Code minimum required flexural reinforcement will be used. Splices will be provided at 3 ft. below the top of the wall. This depth corresponds to the depth at shallow ends for most coastal swimming pools. To provide a failure mechanism at the bottom of the wall near the deep end, another splice will be provided above the floor/wall joint when the depth is 5 feet and more. The depth of 5 feet was chosen so that the bar that extends below the splice at 3 feet could be more than 2 feet long. The vertical joints will allow the walls to breakaway vertically. The splices will allow the walls to break horizontally.

BREAKAWAY POOL DESIGN

Swimming pools have been built from several materials, which include concrete, fiberglass, timber, masonry, and vinyl. The FDEP considers timber pools as frangible because they are vinyl-lined. The authors spoke with many pool builders about typical construction practices. Most of them liked the on-site ease and rapid construction of concrete or pressure sprayed (gunite) pools.

The authors suggest that fiberglass or timber be used for frangible pools because they breakaway easily and result in smaller and lighter debris. However, for pool owners who wish to build a concrete pool, the authors present a recommended breakaway design methodology. It is entirely possible to develop other equally effective breakaway designs for concrete pools.

EVERYDAY LOAD DESIGN

A swimming pool must be able to withstand everyday maximum loading. For pools situated above ground, these loads include the water load inside the pool when it is full, as shown in Fig. 1. The total load is:

$$W_A = 0.5\gamma_w H^2 \text{ per unit width of wall} \quad (1)$$

in which γ_w = unit weight of water, and H = height of pool.

The bending moment at the pool base is given by:

$$M_A = 0.083\gamma_w H^3 \text{ per unit width of wall} \quad (2)$$

For a below ground pool, the maximum everyday forces are caused by soil outside the pool when it is empty, as shown in Fig. 2. This force and the corresponding moment are expressed as the following for a 32° coefficient of internal friction for soil:

$$W_B = 0.235\gamma_s H^2 \text{ per unit width of wall} \quad (3)$$

$$M_B = 0.078\gamma_s H^3 \text{ per unit width of wall} \quad (4)$$

in which γ_s = unit weight of soil.

The ground water table was assumed to be low, which would cause negligible force on a below ground pool. For higher water levels the pool should remain filled with water to prevent it from floating up. A floating pool is likely to crack and will rarely settle back in the original position after flooding subsides.

The everyday maximum forces and moments expected on the pool wall are presented in Tables 2(a) and (b). The waterload on an above ground pool is slightly higher than the soil load on a below ground pool; the two forces just act in opposite directions. Therefore, only the design of an above ground pool with water load is presented herein.

Design shear forces and moments with ACI load factors on a 2 foot width of pool wall are shown in Table 2(c). Corresponding vertical steel design at the splice (3 feet from top) and at the bottom (6 feet from top) are also presented. Two #4 bars are needed at the splice to satisfy ACI code limitation for maximum spacing. Typical sections chosen for the breakaway concrete pool are shown in Fig. 1. Wall panel design layout showing joints and bar splices are shown in Fig. 2. Pool wall and floor reinforcement details are shown in Fig. 3.

WAVE LOADING

The forces from breaking waves may be found from the Minikin Method, which is "based on observations of full-scale breakwaters and the results of Bagnold's study," and is presented in the Shore Protection Manual (1984). Because this method can result in wave forces that may be 15 to 18 times those for nonbreaking waves, the Shore Protection Manual warns that this method be used with caution. The variables are: the depth to the still water level (SWL) at the pool wall, the slope of the shore in front of the pool, and the wave period. The forces and moments on a typical pool wall for a 6 second conservative wave period are presented in Table 3.

Non-breaking waves obviously cause smaller forces on a pool than breaking waves. The non-breaking wave forces can be estimated from the Miche-Rundgren Method contained in the Shore Protection Manual. These forces depend on the free wave height, the depth of water to the SWL, the wave period, the wave reflection coefficient and the height of the wall above ground. The calculated non-breaking wave forces for a 6 second wave, a reflection coefficient of unity and the wall height equal to the water depth are presented in Table 4. The last condition represents no overtopping of the wall by the wave.

VERIFICATION OF BREAKAWAY

A comparison of Tables 2 and 3 reveals some interesting conditions. Breaking waves during a storm are expected to generate shear forces and bending moments which in most cases will easily exceed those caused by the everyday forces. This observation is valid for most water depths of 4 ft. or more and wall heights of 5 ft. or more. Non-breaking waves generate forces and moments on the pool wall which may exceed the everyday forces and moments if the water depth is generally 6 ft. or more or the wave height is 2.5 ft. or more. These critical water/wave depths are situation specific, i.e., they may occur if the shore slope is high and the pool is close to the water line. The wave height also depends on the intensity of the storm.

It may be inferred that the breakaway pool design described herein is expected to perform well in many coastal situations under an intense storm. The strength of the designed pool under wave action is found to be less than the strength needed for everyday loading, for most conditions. Therefore, the pool is expected to withstand the daily normal loading, while it is expected to breakaway along lines of weaknesses under extreme wave action. It is understood that many simplifying assumptions were made and parametric values assumed in the design of the breakaway pool, changes in which will affect the design and the validity of the breakaway criteria. Only a conceptual breakaway pool design is detailed herein, which shows that it is possible to design a frangible pool for coastal areas.

IMPACT OF DEBRIS ON FOUNDATION

If a pool is designed to be frangible, it is likely to breakaway in several pieces during an extreme flooding. It is possible that the broken debris may be carried by wave action and impact on

the adjacent house or foundation. The foundation should be designed with proper consideration for this impact force from a frangible pool.

There are many variables which are likely to influence the magnitude of the debris impact force, such as the size of the pieces that will break away, the velocity of the broken pieces, the wave height and wave depth, the amount of time the broken pieces remain in contact with the foundation, and the manner in which the pieces come in contact with the foundation. The position of the pieces in the wave is also a factor for transitional or deep water.

Simplifying assumptions were made in order to develop an expression for the debris impact force on adjoining foundations. It was assumed that the pool wall will break into 2 foot by 3 foot by 6 inch thick pieces (according to the breakaway design for concrete pools developed in this study) and will impact at a velocity equal to the velocity of the water (a conservative assumption).

From Impulse-Momentum relationships (Beer, 1988):

$$\int F dt = mv \quad (5)$$

in which F = impact force, dt = increment of time, m = mass of broken piece, and v = velocity of piece when it comes in contact with the foundation.

The velocity of the piece, assuming shallow water conditions, is as follows (Herbich, 1984):

$$v = H/2 (g/d)^{1/2} \cos\theta \quad (6)$$

in which H = wave height, d = depth to SWL, θ = phase angle of wave, and g = acceleration due to gravity = 32.2 ft/sec².

For maximum velocity, assuming $\theta = 0$ degrees:

$$\int F dt = 13.98 (0.5H)(g/d)^{1/2} \quad (7)$$

Values of the impulse force from Eq. 7 for various values of $\sqrt{H/d}$ are shown in Table 5. If a frangible coastal concrete pool is designed, the adjacent foundation should be designed to withstand debris impact forces similar to the presentation in this table.

CONCLUSIONS

The following conclusions may be made based on the findings of the study:

1. There have been no previous or continuing studies which address frangibility criteria for coastal swimming pools.
2. Most coastal swimming pools are rectangular; the average dimensions are about 17 feet by 34 feet. Almost all coastal pools are made of concrete or gunite. The average distance from the CCCL is 112.2 feet; and the average maximum depth is 5.75 feet. The average storm surge is 6.7

feet above the grade. These conclusions are based on a survey of 23 coastal pools from the Florida Department of Environmental Protection permit files.

3. Most coastal pool builders like the ease of working with gunite.
4. It is feasible to theoretically and practically design and construct a good and safe breakaway swimming pool made of concrete. A good breakaway concrete pool design includes vertical joints and splices in the reinforcing steel.
5. Scour that causes undermining of the pool wall may cause failure. For example, for the concrete swimming pool design, a 6 foot wall undermined approximately 3 feet will fail due to the weight of the water inside the pool.
6. The debris from a breakaway pool may impact the pool or house foundation due to wave and current action. The foundation must be designed to withstand the debris impact force from a frangible pool.
7. The authors recommend that for high hazard areas, in which frangibility is desired, fiberglass or plywood be used for the pools. If the pool must be concrete, a design such as the one presented in this report may be used as an option. If a concrete pool is to be situated above ground, the authors recommend that the pool be no more than 3 feet above ground.

ACKNOWLEDGEMENT

The research work reported in this paper was funded by a grant from the Federal Emergency Management Agency (FEMA) and the Florida Department of Environmental Protection (FDEP).

LITERATURE CITED

- American Concrete Institute (ACI), Building Code Requirements for Reinforced Concrete, ACI 318-89, Detroit, Michigan, 1989.
- Beer, F.P., and Johnston, E.R. Jr., Vector Mechanics for Engineers, 5th ed. New York: McGraw-Hill, Inc., 1988.
- Herbich, J.B., Schiller, R.E., Dunlap, W.A., and Watanabe, R.K., Seafloor Scour: Design Guidelines for Ocean-Floor Structures. New York and Basel Switz: Marcel Dekker Inc. 1984.
- Shore Protection Manual, Volume II, 4th ed., Coastal Engineering Research Center, Department of the Army, 1984.

These figures were used in this paper:

dt = increment of time;

F = impact force;

g = acceleration due to gravity;

H = wave height;

M_A = bending moment at pool base (above ground pool);

M_B = bending moment at pool base (below ground pool);

m = mass of broken piece;

W_A = water load inside pool when full (above ground pool);

W_B = water load inside pool when full (below ground pool);

γ_s = unit weight of soil;

γ_w = unit weight of water;

θ = phase angle of wave;

v = velocity of piece on impact.

Table 1. Florida Coastal Swimming Pool Characteristics

Pool #	Shape	Dimensions	Orientation to CCCL	Loc. Rel. to CCCL	Max. Depth	100 Year Storm Surge (NGVD)	Bottom Elev. (NVGD)	Material
1	Rect.	20'x40'	10'//	<47' seaward	6'	13.2'		shotcrete
2	Rect.	18'x26'	18'//	<158'	6'	12.8'	5'	shotcrete
3	Rect.	17'x42.5'	42.5'//	<162.5'	6'	12.3'	10.5'	conc. shell on grade
4	Rect.	18'x38'	38'//	<9'	5'	12.3'	13'	conc. shell & stem wall
5	Rect.	20'x40'	40'//	<77'	8'		4.5'	reinf. gunite shell
6	Rect.	20'x60'	60'//	<64'	8'	12.6'	0.0'	6" conc. shell
7	Rect.	20'x32'	20'//	<7'	6'	11.3'	10.4'	5" reinf. conc. shell
8	Rect.	15'x40'	40'//	<125'	6'	11.4'	16'	conc. shell
9	Rect.	18'x38'	38'//	<183'	6'	12.2'	-1.0'	6" reinf. conc. shell
10	Kidney	14'x28'	28'//	<340'	6'	14.8'	0.6'	4-6" conc. shell
11	Rect.	14'x28'	14'//	<9'	5.5'	14.7'	1.2'	6" conc. shell
12	Rect.	10'x28'	28'//	<300'	4'	12.2'	5.8'	manufact. fiberglass
13	Rect.	17'x29'	29'//	<75'	6'	12.5'	4.7'	8" conc. shell
14	2 Rect.	12'-18'x24'	24'//	<94'	5.5'	13.1'		5" conc. shell
15	Kidney	20'x31'	31'//	<132'			12'	conc. shell
16	Rect.	19'x41'	19'//	<138"	6'	13.1'	6.5'	6" conc. slab shell
17	Odd	35'x44'	35'//	<216'	8'	12.3'	2.0'	conc. shell
18	Rect.	18'x40'	8'//	<60'	4.5'		6.0'	conc. shell
19	Round	16'x20'	16'//	<20'	5'	14.7'	0.0'	6" gunite shell
20	Rect.	14'x27'	app. 45 deg.	<19'	5'	12.5'	4.3'	6" shotcrete
21	Odd	22'x33'	33'//	<295'	5.5'	12.8'	2.0'	conc. shell
22	Oval	16'x26'	26'//	<38'	2.5'		11'	reinf. gunite shell
23	Kidney	15'x36'	36'//	<12'	6'	11.5'	9.8'	4" -6" conc. shell

Table 2. Everyday Maximum Forces and Moments on Pool Wall

Wall Height (ft)	Above Ground Pool (lb/ft width)	Below Ground Pool (lb/ft width)
4	499	451
5	780	705
6	1123	1015
7	1529	1382

(a) Everyday Forces

Wall Height (ft)	Above Ground Pool (lb/ft width)	Below Ground Pool (lb/ft width)
4	666	602
5	1300	1175
6	2246	2030
7	3567	3224

(b) Everyday Moments at the Base

Depth from Pool Top (ft)	Ultimate Shear (lb)	Ultimate Moment (lb-ft)	Reinforcement Design
3	786	786	1 - #4 (2 - #4 provided)
6	3145	6290	3 - #4

(c) Ultimate Shears and Moments in Wall (on 2' width)

Table 3. Breaking Wave Forces & Moments on Pool Wall

Shore Slope	Depth to SWL (ft)						
	1	2	3	4	5	6	7
0.00	31	125	281	499	780	1123	1529
0.01	136	683	1787	3552	6083	9506	13881
0.02	140	709	1861	3712	6380	10038	14739
0.03	146	741	1950	3896	6710	10611	15648
0.04	153	779	2049	4097	7065	11221	16601
0.05	162	820	2157	4312	7443	11861	17607
0.07	181	912	2394	4780	8258	13236	19726
0.10	213	1067	2792	5561	9607	15478	23187

(a) Forces on Pool Wall (lb/ft)

Shore Slope	Depth to SWL (ft)						
	1	2	3	4	5	6	7
0.00	10	83	281	666	1300	2246	3567
0.01	102	1100	4459	12078	26257	49853	85766
0.02	105	1142	4656	12660	27633	52854	91462
0.03	110	1199	4898	13337	29176	56112	97537
0.04	117	1267	5173	14088	30852	59593	103942
0.05	124	1343	5475	14900	32647	63273	110713
0.07	142	1514	6146	16681	36547	71217	125072
0.10	172	1810	7291	19690	43075	84295	148702

(b) Moments on Pool Wall (lb-ft/ft)

Table 4. Non-breaking Wave Forces & Moments on Pool Wall

Free Wave Height (ft)	Depth of Water from SWL (ft)						
	1	2	3	4	5	6	7
0.5	48.4	110.9	178.6	250.0	300.9	>	>
1.0	>	191.7	306.0	428.7	553.1	677.1	795.9
1.5	>	>	426.6	598.1	766.7	953.6	1132.1
2.0	>	>	537.6	750.0	975.5	1206.7	1434.7
2.5	>	>	>	894.4	1160.9	1441.7	1728.7
3.0	>	>	>	>	1336.6	1661.2	1995.9
4.0	>	>	>	>	>	2076.8	2489.0

(a) Forces on Pool Wall

Free Wave Height (ft)	Depth of Water from SWL (ft)						
	1	2	3	4	5	6	7
0.5	19.0	97.9	243.3	461.6	631.7	>	>
1.0	>	152.1	387.5	760.3	1257.5	1866.8	2552.7
1.5	>	>	514.6	1007.5	1671.1	2615.8	3715.6
2.0	>	>	634.3	1222.7	2045.5	3179.2	4554.1
2.5	>	>	>	1428.5	2390.5	3665.2	5317.9
3.0	>	>	>	>	2692.6	4124.1	5970.7
4.0	>	>	>	>	>	5056.0	7179.4

(b) Moments on Pool Wall

> Beyond Range for Nonbreaking Waves

Table 5. Impulse on Foundation From Debris

H/d*	Impulse (J Fdt) (lb-sec)
0.5	20
1.0	40
1.5	60
2.0	80
2.5	100
3.0	120
3.5	140
4.0	160
4.5	180
5.0	200

* H and d are in feet